



Instruction Manual

Multi-Spray Unit Air-Assisted Airless Spray Unit

MSU-111N (13:1 Stand Mount)

MSU-113N (13:1 Cart Mount)

MSU-114N (13:1 Wall Mount)

MSU-323N (17:1 Cart Mount)

MSU-324N (17:1 Wall Mount)

This instruction manual contains **IMPORTANT WARNINGS, CAUTIONS** and **INSTRUCTIONS**.
Read and understand this instruction manual before use and retain for reference.



Important Information – Safety Precautions

- Equipment in this instruction manual is exclusively for coating purposes. Do not use for other purposes.
- Read and understand this instruction manual. The operator shall fully understand the requirements stated within the instruction manual including important warnings, cautions, operation and correct handling.
- Incorrect operation or mishandling can cause serious bodily injury, death, fire or explosion.



Safety precautions

- The safety precautions in this instruction manual describe the minimum necessary information. Be sure to follow national and local regulations on fire prevention, electricity and safety as well as your own corporate regulations.
- Pay special attention to sections shown with the symbols below. The explanations of the symbols are as follows:

Warning and caution

 WARNING	This symbol indicates that a potentially hazardous situation may result in serious injury or death if not followed.
 CAUTION	This symbol indicates that a potentially hazardous situation may result in minor or moderate injury or damage to equipment if not followed.

Types of symbols

	This symbol indicates you must use caution. Explanation will be given near symbol.
	This symbol indicates warning may cause physical harm. Explanation will be given near symbol.
	This symbol indicates recommendations or requirements. Explanation will be given near symbol.

Notes

 IMPORTANT	This symbol indicates important information needed to achieve full performance and function of the equipment.
HINT	This symbol indicates useful knowledge and advice.

ANEST IWATA shall not be responsibility for any injury or damage caused by the disregard of warnings, cautions or the instructions contained in this instruction manual.

Important Information - Safety Precautions

- 1. Safety Warnings..... 2**
- 2. Specifications..... 4**
- 3. Functions..... 8**
- 4. Setup..... 10**
- 5. Operation..... 12**
- 6. Cleaning..... 14**
- 7. Maintenance..... 15**
- 8. Trouble Shooting..... 16**
- 9. Disassembly and Assembly..... 18**
- 10. Parts List..... 27**
- 11. Spray Gun Nozzle Tip Chart..... 35**

1. Safety Warnings

WARNING

FIRE OR EXPLOSION HAZARD

1. Fluid and/or solvent can be highly flammable or combustible.
 - Use in well-ventilated spray booth.
 - Avoid any ignition sources such as smoking, open flames or electrical hazard.
2. To reduce the risk of static sparking, grounding continuity to the spray equipment, fluid container and object being sprayed must be maintained.



HAZARD CREATED WHILE COATING MATERIALS ARE ATOMIZED AND SPRAYED

1. Toxic vapors produced by spraying certain materials can cause intoxication and serious damage to health.
 - Use in well-ventilated areas.
 - Always wear protective clothing, eyewear, gloves and respirator to prevent toxic vapor, solvent and paint from coming into contact with your eyes and skin.



PRESSURIZED FLUID HAZARD - INJECTION HAZARD

1. Pressurized hazardous fluid can cause serious injury or death.
 - Always wear protective clothing, eyewear, gloves and respirator.
 - Never spray toward a person or animals and never pull the trigger of the spray gun near the body.
 - Never stop or deflect a fluid leak from the spray equipment or fluid hose with your hand. Be sure to stop the spray equipment according to the correct procedures.
2. Replace hoses immediately, if cracked, damaged, bent, crushed, distorted or worn. Use of such hoses can cause damage.
3. Never bend hoses with a radius of less than 2in. (50mm) or put heavy items on top of hoses.
4. Keep hoses away from sharp edge and moving parts.
5. Be sure to tighten all connections.



MISUSE HAZARD

1. Never touch moving parts.
2. Always release air and fluid pressure when not in use.
3. Always release air and fluid pressure before cleaning, disassembly or service. For emergency stop and to prevent unintended operation, a shut off valve is installed on this unit to stop the air supply.
4. Be sure to use the spray equipment at less than the maximum working pressure. If not, it can cause spray equipment failure, malfunction, serious injury or death.
5. Never modify this unit for any other applications.
6. Never use this unit to spray or supply food products.
7. If operation appears incorrect, immediately stop operation and find the cause.
8. Never use until the problem has been solved.
9. Pay attention to avoid hitting or dropping this unit, especially threaded and seated parts.
10. Never use damaged parts.
11. Repair or replace worn or damaged parts immediately. Always use ANEST IWATA replacement parts.
12. Never operate this unit or disassemble without receiving proper education and training.
13. Wear hearing protection.



OTHER HAZARD

1. Be sure to follow fire prevention, electrical and other local regulations.



CAUTION

1. Never use the following homogenate hydrocarbon solvents.
 - Methyl chloride
 - Dichloromethane
 - 1,2 - dichloromethane
 - Carbon tetrachloride
 - Trichloroethylene
 - 1,1,1 - trichloroethane
2. Be sure to use compatible fluids with the wetted parts of this unit and the spray gun, hoses and fittings. Make sure to review the Material Safety Data Sheet (MSDS) from paint or fluid manufacturer.



IMPORTANT

1. Check to ensure that this unit has not been damaged during transportation.
2. Install this unit in a dry, clean and well-ventilated area.
3. Use clean air filtered through a dryer and a filter finer than 50 microns. If not, it can cause spray equipment malfunction and finish problem.
4. Be sure to follow local guidelines for proper fluid storage procedures.
5. Be sure to follow local guidelines for proper cleaning and fluid disposal procedures.

2. Specifications

2-1. Specifications

2-1-1. 13:1 pump unit

Model		MSU-111N	MSU-113N	MSU-114N
Type		Stand Mount	Cart Mount	Wall Mount
Dimensions (L x W x H)	inch	21.0 x 20.9 x 40.3	19.7 x 20.9 x 40.3	13.0 x 10.9 x 24.6
	mm	533 x 530 x 1023	500 x 530 x 1023	330 x 277 x 626
Weight (without hoses and gun)	lbs	35.3	39.7	28.7
	kg	16	18	13
Plunger Pump Model		PP-7131N (Stainless Steel Model)		
Pressure Ratio		13:1		
Air Inlet		BSPP1/4" (G1/4")		
Air Outlet (to spray gun)		BSPP1/4" (G1/4")		
Fluid Inlet		BSPP1/2" (G1/2")		
Fluid Outlet		BSPP1/4" (G1/4")		
Maximum Inlet Air Pressure		98psi (0.68MPa, 6.8bar)		
Maximum Fluid Working Pressure		1274psi (8.8MPa, 88bar)		
Maximum Fluid Output		0.50gal/min (1.9L/min)		
Maximum Cycle		110cycles/min		
Maximum Fluid Output per Cycle		0.58oz/cycle (17.3mL/cycle)		
Fluid Filter Set (Option)		100mesh		
Suction Filter		50mesh (Optional 100mesh)		
Maximum Fluid Viscosity		300cps (100sec/NK-2, 85sec/Ford#4, 24sec/Zahn#4)		
Wetted Parts		Stainless Steel, G2, HDPE		
Operating Ambient Temperature		41 - 104°F (5 - 40°C)		
Operating Air/Fluid Temperature		41 - 109°F (5 - 43°C)		
Noise Level		81.6dB(A) Measuring point : 1 m backwards from pump, 1.6 m height		
Required compressor (for pump)		1.0 - 3.0hp		

*See spray gun instruction manual about specifications of spray gun.

2. Specifications

2-1-2. 17:1 pump unit

Model		MSU-323N	MSU-324N
Type		Cart Mount	Wall Mount
Dimensions (L x W x H)	inch	19.7 x 20.9 x 40.3	14.5 x 10.9 x 28.9
	mm	500 x 530 x 1023	368 x 277 x 734
Weight (without hoses and gun)	lbs	48.5	37.5
	kg	22	17
Plunger Pump Model		PP-1171CNE (Stainless Steel Model)	
Pressure Ratio		17:1	
Air Inlet		BSPP1/4" (G1/4")	
Air Outlet (to spray gun)		BSPP1/4" (G1/4")	
Fluid Inlet		BSPP1/2" (G1/2")	
Fluid Outlet		BSPP1/4" (G1/4")	
Maximum Inlet Air Pressure		98psi (0.68MPa, 6.8bar)	
Maximum Fluid Working Pressure		1666psi (11.5MPa, 115bar)	
Maximum Fluid Output		0.93gal/min (3.5L/min)	
Maximum Cycle		92cycles/min	
Maximum Fluid Output per Cycle		1.30oz/cycle (38.3mL/cycle)	
Fluid Filter Set		Model:TF-8N, 100mesh	
Suction Filter		50mesh (Optional 100mesh)	
Maximum Fluid Viscosity		300cps (100sec/NK-2, 85sec/Ford#4, 24sec/Zahn#4)	
Wetted Parts		Stainless Steel, G2, HDPE	
Operating Ambient Temperature		41 - 104°F (5 - 40°C)	
Operating Air/Fluid Temperature		41 - 109°F (5 - 43°C)	
Noise Level		86.3dB(A) Measuring point : 1 m backwards from pump, 1.6 m height	
Required compressor (for pump)		1.0 - 5.0hp	

*See spray gun instruction manual about specifications of spray gun.

2. Specifications

2-2. Performance curve

PP-7131N (13:1 pump)

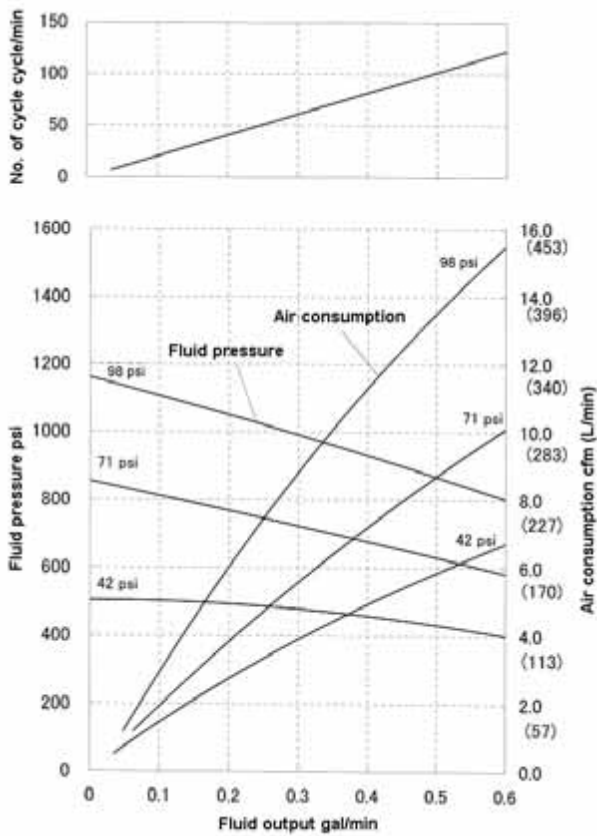

PP-1171CNE (17:1 pump)

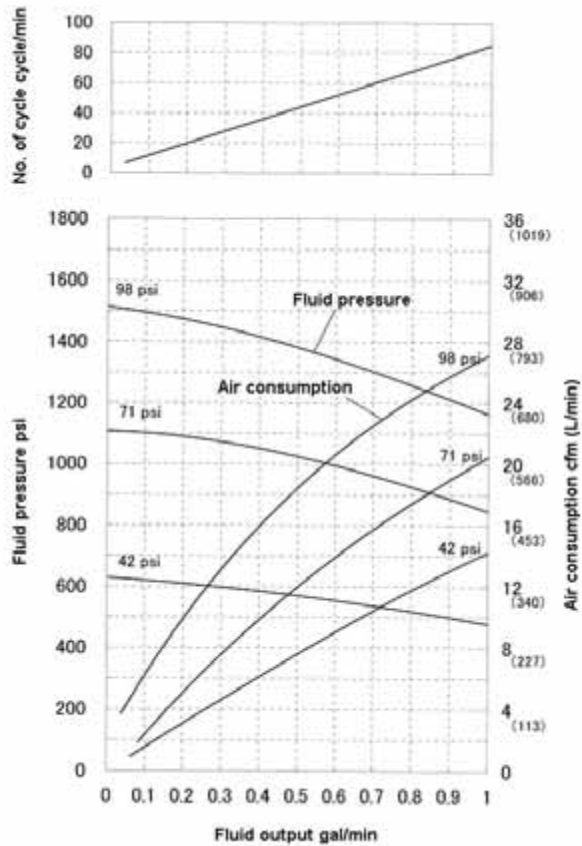

Inlet air pressure: The number with each curve
 Test fluid: Water

How to find fluid pressure

1. Locate specific fluid output along the horizontal axis of the chart.
2. Follow vertical to the intersection with the fluid pressure curve of selected inlet air pressure.
3. Follow left to the vertical axis of the chart to read fluid pressure.

How to find air consumption

1. Locate specific fluid output along the horizontal axis of the chart.
2. Follow vertical to the intersection with the air consumption curve of selected inlet air pressure.
3. Follow right to the vertical axis of the chart to read air consumption.

How to find cycle per minutes

1. Locate specific fluid output along the horizontal axis of the chart.
2. Follow vertical to the intersection with number of cycle curve of top chart.
3. Follow left to the vertical axis of the chart to read cycle per minutes.

Example: PP7131N (13:1 pump) See example to right Fig. A

When inlet air pressure is 71psi and fluid output is 0.3gal/min,

1. Fluid pressure is approx. 700psi
2. Air consumption is approx. 5.5cfm.
3. Cycle per minutes is approx. 60 cycles/min.

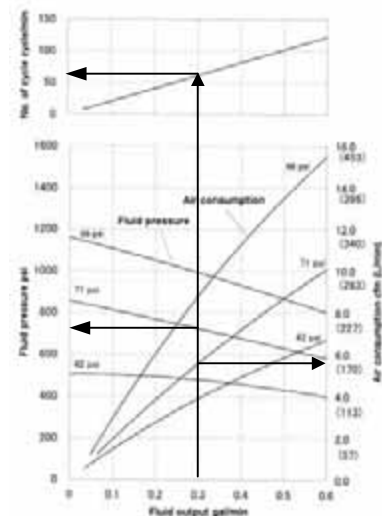

Fig. A

2-3. Model plate



Ref	Description
1	Model name
2	Model
3	Serial Number
4	CE-EX Marking
	<ul style="list-style-type: none"> - Equipment group: II - Category: Gas2G - Area: Gas - Maximum surface temperature: temperature class T6 - X marking <p>Any static electricity discharge from the spray gun is to be diverted to the grounded the conductive air hose as stipulated.</p>
5	Maximum air working pressure
6	Manufacturer

3. Functions

3-1. 13:1 pump unit

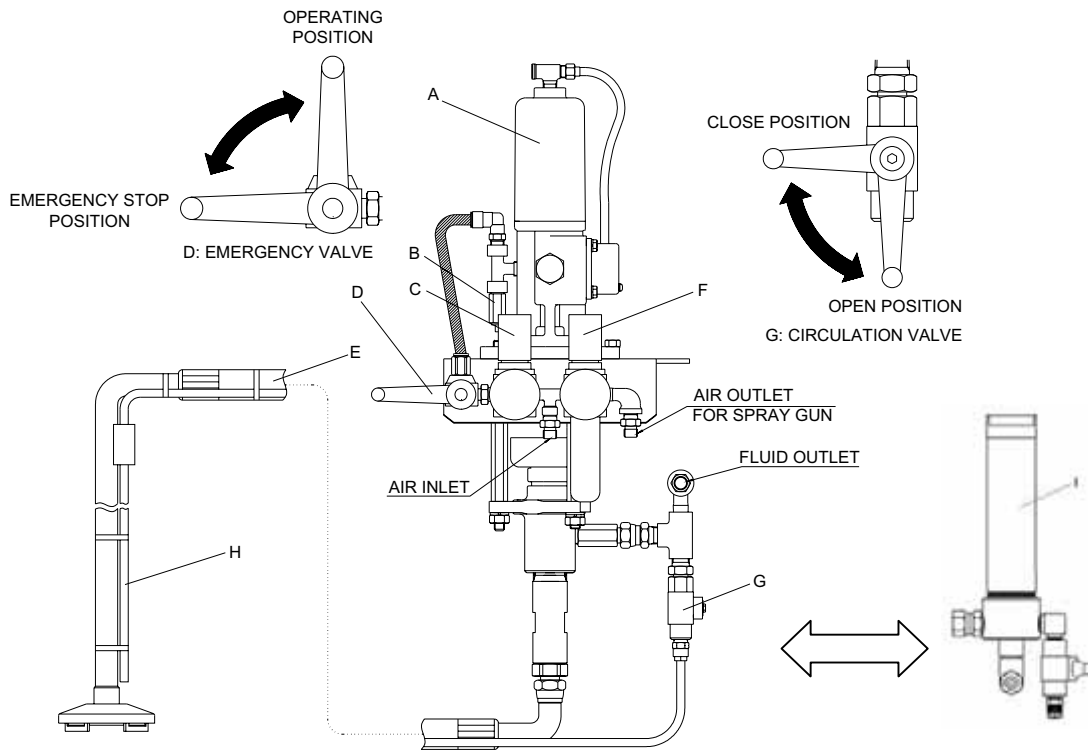

Fig.1: Functions (13:1 pump unit)

	Parts	Function
A	Plunger Pump	PP-7131N, stainless steel model
B	Pop-off Valve	Working pressure: 116psi
C	Air Regulator	For pump operation. with locking knob feature
D	Emergency Valve	Emergency air shut off valve
E	Suction Hose Set	with 50mesh filter
F	Air Filter Regulator	For atomizing air wth locking knob feature
G	Circulation Valve	To circulate or dump fluid
H	Circulation Tube	To circulate or dump fluid
I	Fluid Filter Set (Option)	100mesh

*Spray gun and fluid and air hoses are not included in this unit.

3-2. 17:1 pump unit

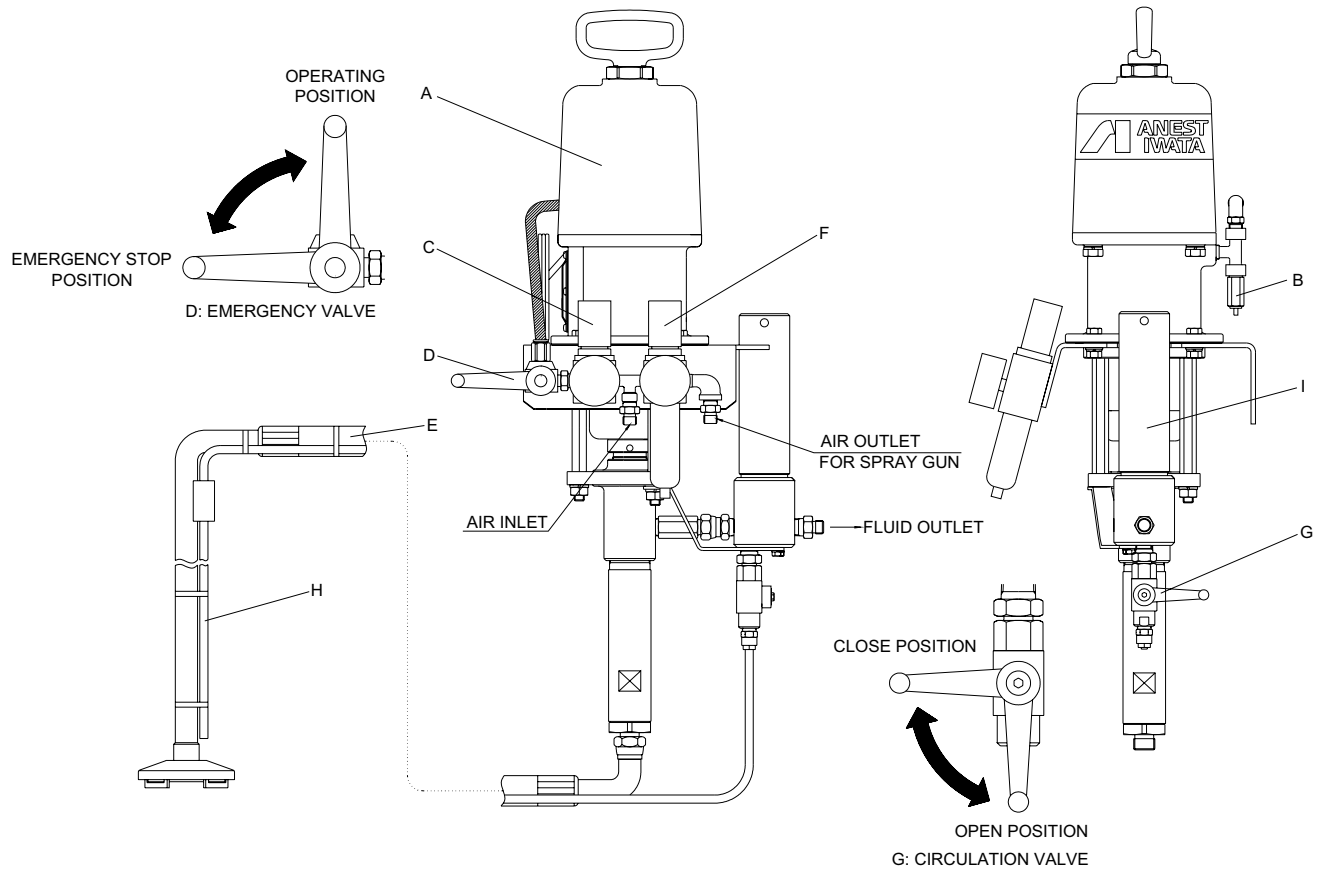

Fig.2: Functions (17:1 pump unit)

	Parts	Function
A	Plunger Pump	PP-1171CNE, stainless steel model
B	Pop-off Valve	Working pressure: 116psi
C	Air Regulator	For pump operation. with locking knob feature
D	Emergency Valve	Emergency air shut off valve
E	Suction Hose Set	with 50mesh filter
F	Air Filter Regulator	For atomizing air. with locking knob feature
G	Circulation Valve	To circulate or dump fluid
H	Circulation Tube	To circulate or dump fluid
I	Fluid Filter Set	TF-8N, 100mesh

*Spray gun and fluid and air hoses are not included in this unit.

4. Setup

4-1. Wall mount unit installation

CAUTION

1. Be careful not to drop this unit during installation.
2. Install this unit on stable wall able to support the weight of this unit, hoses, any accessories and material inside the pump and stress created by pump operation.

Wall mount hole layout

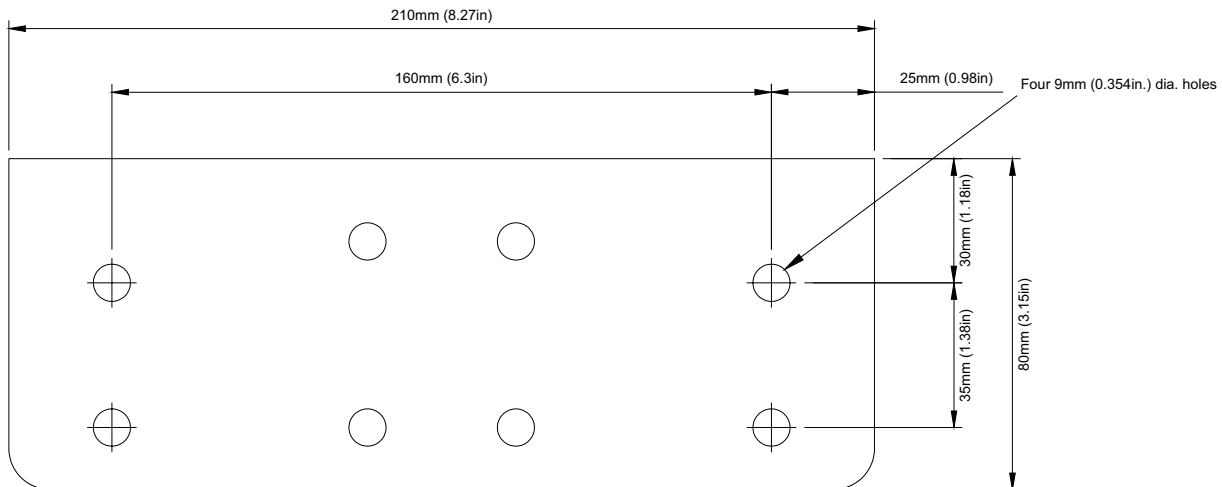

4-2. Setup

WARNING

1. This unit should be operated by adequately trained operators only.
2. To reduce the risk of static sparking, grounding continuity to the spray equipment, fluid container and object being sprayed must be maintained.
3. Be sure to tighten all connections.
4. Be sure to follow fire prevention, electrical and other local regulations.



IMPORTANT

1. Install this unit in a dry, clean and well-ventilated area.
2. Use clean air filtered through a dryer and a filter finer than 50 microns. If not, it can cause spray equipment malfunction and finish problem.

HINT

1. Grounded air hose designed by ANEST IWATA is available.

Refer to **Fig.1** on page 8 or **Fig.2** on page 9 to find reference letters.

1. Place this unit on hard level surface and load uniformly, if stand or cart mount unit.
2. Secure ground wire.
3. Close **Air Regulators** (C and F) fully.
4. Set **Emergency Valve** (D) to "**Emergency Stop**" position and open **Circulation Valve** (G).
5. Connect fluid and air hoses to the outlet fittings of this unit and other end to inlet fittings on spray gun. If hoses or fittings are damaged, replace immediately.
6. Connect air supply hose to inlet of unit.

4-3. Checking operation **WARNING**

1. Never touch moving parts.

 **IMPORTANT**

1. Do not keep pump idling for extended periods of time. Prolonged idle operation may cause premature pump failure.

Refer to **Fig.1** on page 8 or **Fig.2** on page 9 to find reference letters.

1. Check **Fluid Filter Set** (I) if installed, suction filter installed on **Suction Hose Set** (E) and filter set installed on spray gun. If they are clogged, clean or replace.
2. Close **Air Regulators** (C and F) fully.
3. Open **Circulation Valve** (G).
4. Set **Emergency Valve** (D) to “**Operating**” position.
5. Turn on the air supply to the unit.
6. Remove **Suction Hose Set** (E) from the pump fluid inlet and adjust **Air Regulator** (C) to 22 - 73psi (0.15 - 0.5MPa, 1.5 - 5bar) slowly.
7. After pump is running, cover fluid inlet fitting underneath the pump with your palm and feel for suction to make sure that pump is working. If not, see **8. Trouble Shooting** on page 16.
8. Set **Emergency Valve** (D) to “**Emergency Stop**” position to make sure that pump operation stops.
9. Close **Air Regulators** (C and F) fully.
10. Connect **Suction Hose Set** (E) and **Circulation Tube** (H). If they are clogged or damaged, clean or replace.

5. Operation

WARNING

1. Use in well-ventilated spray booth.
2. Avoid any ignition sources such as smoking, open flames or electrical hazard.
3. Always wear protective clothing, eyewear, gloves and respirator.
4. Never spray toward a person or animals and never pull the trigger of the spray gun near the body.
5. Never stop or deflect a fluid leak from the spray equipment or fluid hose with your hand. Be sure to stop the spray equipment according to **5-4. Emergency stopping** procedure on page 13.
6. Never touch moving parts.
7. Always release air and fluid pressure when not the use.
8. Always release air and fluid pressure before cleaning, disassembly or service. For emergency stop and to prevent unintended operation, a shut off valve is installed on this unit to stop the air supply.
9. Be sure to use the spray equipment at less than the maximum working pressure. If not, it can cause spray equipment failure, malfunction, serious injury or death.
10. Never modify this unit for any other applications.
11. Never use this unit to spray or supply food products.
12. If operation appears incorrect, immediately stop operation and find the cause. See **8. Trouble Shooting** on page 16.
13. Never use until the problem has been solved.



CAUTION

1. Be sure to use compatible fluid and cleaning fluid with the wetted parts of this unit.

5-1. Flushing

IMPORTANT

1. Flush fluid passages of this unit completely with cleaning fluid before first use and every time after use. If not, it can cause finish problem and pump malfunction.
2. Always fully close or fully open circulation valve. Opening valve halfway can cause seat wear, fluid leakage and lack of fluid pressure.
3. Be sure to follow local guidelines for proper cleaning and fluid disposal procedures.

Refer to **Fig.1** on page 8 or **Fig.2** on page 9 to find reference letters.

1. Remove air cap set and nozzle tip from spray gun.
2. Close **Air Regulators** (C and F) fully.
3. Open **Circulation Valve** (G).
4. Set **Emergency Valve** (D) to “**Operating**” position.
5. Put **Suction Hose Set** (E) and **Circulation Tube** (H) into cleaning fluid container.
6. Adjust **Air Regulator** (C) to 22 - 73psi (0.15 - 0.5MPa, 1.5 - 5bar) slowly.
7. Circulate cleaning fluid or dump to another container through **Circulation Tube** (H).
8. Point the spray gun toward to container and pull the trigger of the spray gun. Be sure that compressed air is not supplied to the spray gun before pulling the trigger.
9. Close **Circulation Valve** (G).
10. Circulate cleaning fluid or dump to another container through the spray gun.
11. After flushing, lift **Suction Hose Set** (E) from container and keep operating pump until air comes out of spray gun.
12. Open **Circulation Valve** (G) and release the trigger of spray gun.
13. Keep operating until air comes out from **Circulation Tube** (H).
14. Close **Air Regulators** (C and F) fully.

5-2. Preparing for spraying

IMPORTANT

1. Always fully close or fully open the circulation valve. Opening the valve halfway can cause seat wear, fluid leakage and lack of fluid pressure.

Refer to **Fig.1** on page 8 or **Fig.2** on page 9 to find reference letters.

1. Remove air cap set and nozzle tip from spray gun.
2. Close **Air Regulators** (C and F) fully.
3. Open **Circulation Valve** (G).
4. Set **Emergency Valve** (D) to “**Operating**” position.
5. Put **Suction Hose Set** (E) and **Circulation Tube** (H) into fluid container.
6. Adjust **Air Regulator** (C) to 22 - 73psi (0.15 - 0.5MPa, 1.5 - 5bar) slowly.
7. Circulate fluid through **Circulation Tube** (H) until fluid does not contain bubbles.
8. Point spray gun toward to container and pull trigger of spray gun. Be sure that compressed air is not supplied to the spray gun before pulling the trigger.
9. Close **Circulation Valve** (G).
10. Circulate fluid through the spray gun until fluid does not contain bubbles.
11. Release the trigger of spray gun.

5-3. Spraying

IMPORTANT

1. See spray gun instruction manual for spray gun operation.

HINT

1. Half fill compatible solvent into wet cup to increase pump life.

Refer to **Fig.1** on page 8 or **Fig.2** on page 9 to find reference letters.

1. Place specified nozzle tip on spray gun.
2. Adjust **Air Regulators** (C and F) to specified pressure.
3. Start spraying.

5-4. Emergency stop

Refer to **Fig.1** on page 8 or **Fig.2** on page 9 to find reference letters.

1. Set **Emergency Valve** (D) to “**Emergency Stop**” position and open **Circulation Valve** (G).

5-5. Stopping operation

HINT

1. Position plunger pump at the end of down stroke to increase pump life when not in use.

Refer to **Fig.1** on page 8 or **Fig.2** on page 9 to find reference letters.

1. Close **Air Regulators** (C and G) fully.
2. Open **Circulation Valve** (G) slowly and pull the trigger of the spray gun. Make sure fluid and air pressure are at “0”.

6. Cleaning

WARNING

1. Use in well-ventilated spray booth.
2. Avoid any ignition sources such as smoking, open flames or electrical hazard.
3. Always wear protective clothing, eyewear, gloves and respirator.
4. Never spray toward a person or animals and never pull the trigger of the spray gun near the body.
5. Never stop or deflect a fluid leak from the spray equipment or fluid hose with your hand. Be sure to stop the spray equipment according to **5-4. Emergency stopping** procedure on page 13.



CAUTION

1. Be sure to use compatible cleaning fluid with the wetted parts of this unit.

IMPORTANT

1. Flush fluid passage of this unit completely with cleaning fluid every time after use. If not, it can cause finish problem and pump malfunction.
2. Always fully close or fully open the circulation valve. Opening the valve halfway can cause seat wear, fluid leakage and lack of fluid pressure.
3. Be sure to follow local guidelines for proper cleaning and fluid disposal procedures.

HINT

1. Position plunger pump at the end of down stroke to increase pump life when not in use.

Refer to **Fig.1** on page 8 or **Fig.2** on page 9 to find reference letters.

1. Remove nozzle tip from spray gun.
2. Clean fluid passage of pump and spray gun. Refer to **5-1. Flushing** procedure on page 12.
3. Place nozzle tip to spray gun and spray cleaning fluid through nozzle tip to clean inside of nozzle tip.
4. Clean **Fluid Filter Set** (I, if installed), suction filter installed on **Suction Hose Set** (E) and filter set installed on spray gun. Replace if necessary.

7-1. Maintenance cycle

Daily	<ol style="list-style-type: none">1. Clean fluid passage of pump and spray gun, fluid filters and nozzle tip of spray gun.2. Check for worn, damaged or broken parts.3. Drain water from air filter regulator.
Every 50 hours	<ol style="list-style-type: none">1. Clean fluid passage of pump and filters if fluid contains lots of pigments and pump is run continuously.
Every 100 hours	<ol style="list-style-type: none">1. Clean fluid passage of pump and filters, if pump is run continuously.
Every 300 hours	<ol style="list-style-type: none">1. Tighten V-packing (upper) of plunger pump.
Every 500 hours	<ol style="list-style-type: none">1. Put general-purpose grease on the moving parts of air motor.
Every 1,000 hours	<ol style="list-style-type: none">1. Overhaul.2. Replace parts with repair service kit. The parts included in the repair service kit are shown in 10. Parts List on page 29 - 32.3. Replace any other worn or damaged parts if necessary.

7-2. How to tighten V-packing (upper) of plunger pump

IMPORTANT

1. If wet cup is over tightened, it can cause the V-packing (upper) to wears early and the pump will not operate.

1. Tighten wet cup by using included tool or a screwdriver every 300 hours and when fluid leaks through wet cup.

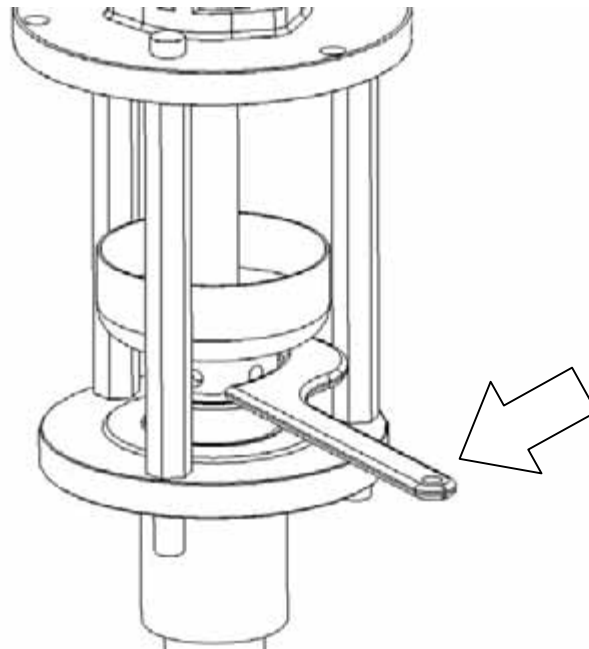

8. Trouble Shooting

Refer to **Fig.1** on page 8 or **Fig.2** on page 9 and **10. Parts List** on page 29 - 35 to find reference letters and numbers.

No.	Problems	Causes	Solutions
1	Pump does not operate.	Air pressure is not supplied to the unit.	Check air compressor and hoses. Check emergency valve.
		Pump operating air pressure is too low.	Increase supplied air pressure. Increase air pressure at Air Regulator (C) .
		V-packing (upper, 2-45/3-46 or lower, 2-49/3-54) is over tightened.	Loosen Wet Cup (2-42/3-40) *1 or Valve Holder Nut (2-47/3-50) . *2
		Parts of air motor are worn or damage.	Replace parts. *2
		Parts of air motor are not assembled correctly.	Reassemble air motor. *2
		Pump frozen (supplied air contains too much moisture).	Eliminate air moisture by using a dryer or water trap.
		Exhaust hole of pump is blocked.	Clean.
		Switch Block (2-17) is installed in the incorrect direction.	Reassemble. *2
		2	Pump operation unstable. Fluid output is low. Fluid does not come out during pump operation.
Fluid Filter (6-5/7-3) , Suction Filter (8-5) or spray gun filter is clogged.	Clean or replace.		
Suction Hose Set (E) is clogged.	Clean or replace.		
V-packing (upper, 2-45/3-46 or lower, 2-49/3-54) is worn or damaged,	Replace. *2		
V-packing (upper, 2-45/3-46 or lower, 2-49 / 3-54) is installed in the incorrect direction.	Reassemble. *2		
V-packing (upper, 2-45/3-46) is over tightened or loose.	Loosen or tighten Wet Cup (2-42/3-40) . *1		
V-packing (lower, 2-49/3-54) is over tightened or loose.	Loose or tighten Valve Holder Nut (2-47/3-50) . *2		
Pump frozen (supplied air contains too much moisture).	Eliminate air moisture by using a dryer or water trap.		
Ball (upper, 2-51/3-55 or lower, 2-57/3-60) sticks on valve.	Clean. *2		
Valve Holder Set (2-53/3-56) or Valve Adaptor Set (2-58/3-61) is worn or damaged or paint is built up.	Replace or clean. *2		
Fluid or air passage inside pump is clogged.	Clean.		
Nozzle tip or filter on spray gun is clogged.	Clean or replace. See instruction manual of spray gun.		
Fluid contains air.	See No.3 on next page.		
Air leaks from air motor of pump. (Not exhausting air)	See No.6 on next page.		

8. Trouble Shooting

No.	Problems	Causes	Remedies
3	Paint contains air.	Air has not been released.	Refer to 5-2. Preparing spraying procedure on page 13.
		Suction Hose Set (E) or Valve Adaptor Set (2-58/3-61) is loose.	Tighten.
		Packing (lower, 2-56/3-59) is worn.	Replace. *2
		Fluid contains air by over agitating.	Adjust agitator.
4	Pulsation or variance within spray pattern.	Fluid pressure is too low.	Increase fluid pressure at Air Regulator (C) .
		Fluid Filter (6-5/7-3) , Suction Filter (8-5) or spray gun filter is clogged.	Clean or replace.
		Valve Holder Set (2-53/3-56) or Valve Adaptor Set (2-58/3-61) is worn or damaged or paint is built up.	Replace or clean. *2
		V-packing (lower, 2-49/3-54) is loose.	Tighten. *2
		Exhaust hole of pump is blocked.	Clean.
		Nozzle tip is worn or orifice size is too large.	Replace or choose smaller orifice size. *3
		Fluid or air is leaking.	Find leak and fix.
5	Paint leaks from fluid hose or joint.	Fluid hose or joint is loose or damaged.	Tighten or replace.
		Paint builds up on seat of fluid joint.	Clean or replace.
	Paint leaks from the Wet Cup (2-42/3-40) .	Wet Cup (2-42/3-40) is loose.	Tighten. *1
		V-packing (upper, 2-45/3-46) is worn or damaged.	Replace. *2
	Paint leaks from between Suction Body (2-40/3-47) and the Suction Tube (2-54/3-58) .	Suction Tube (2-54/3-58) is loose.	Tighten. *2
		Packing (upper, 2-52/3-57) is worn or damaged.	Replace. *2
	Paint leaks from Fluid Filter Set (I) .	Cylinder (6-2/7-1) is loose.	Tighten.
		Packing (6-6) or O-ring (7-5) is worn or damaged.	Replace.
6	Air leaks from air hose or joint.	Air hose or fitting is loose or damaged.	Tighten or replace.
	Air leaks from air motor.	O-ring (2-16/2-20/3-5/3-26) is worn or damaged.	Replace. *2
		Packing (2-34/3-2) is worn or damaged.	Replace. *2
		Pipe Nut (2-9) is loose or Sleeve (2-10) is worn or damaged.	Tighten or replace.

*1 Refer to **7-2. How to tighten V-packing (upper) of plunger pump** on page 15.

*2 Refer to **9. Disassembly and Assembly** on page 18.

*3 Refer to **11. Nozzle Chart** on page 35.

9. Disassembly and Assembly

WARNING

1. Always release air and fluid pressures before cleaning, disassembly or service.
2. Pay attention to avoid hitting or dropping this unit, especially threaded and seated parts.
3. Never use damaged parts.
4. Repair or replace worn or damaged parts immediately. Always use **ANEST IWATA** replacement parts.
5. Never modify this unit for any other applications.
6. Do not disassemble or assemble without receiving proper education and training.

9-1. Disassembly

9-1-1. Air motor section

IMPORTANT

1. Do not damage or bend air motor rod, changeover rod and rod and be sure to check that these are free of foreign matter. It can cause pump malfunction.

a) PP-7131N (13:1 pump)

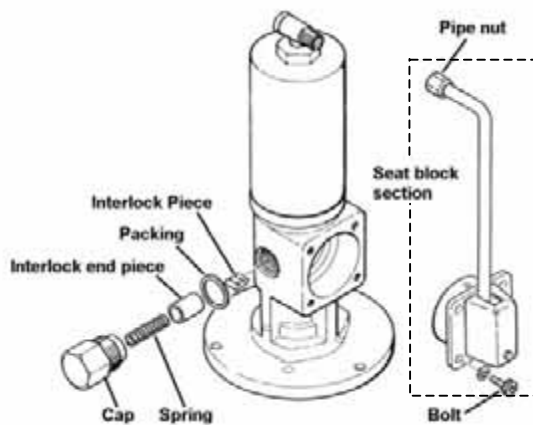

1. Loosen the four bolts and the pipe nut and remove the seat block section from the air motor body.
2. Loosen the cap and remove the following parts.
 - Spring
 - Interlock end piece
 - Packing
 - Interlock piece

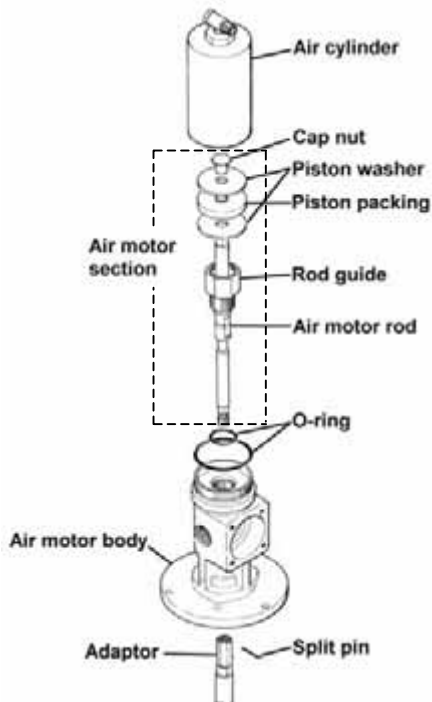

3. Loosen the air cylinder with a wrench and remove.
4. Remove the split pin.
5. Loosen the air motor rod and remove.
6. Loosen the rod guide and remove the air motor rod section from the air motor body.
7. Loosen the cap nut and remove the following parts.
 - Piston washer
 - Piston packing
 - O-ring
8. Remove the rod guide from the air motor rod.

9. Disassembly and Assembly

b) PP-1171CNE (17:1 pump)

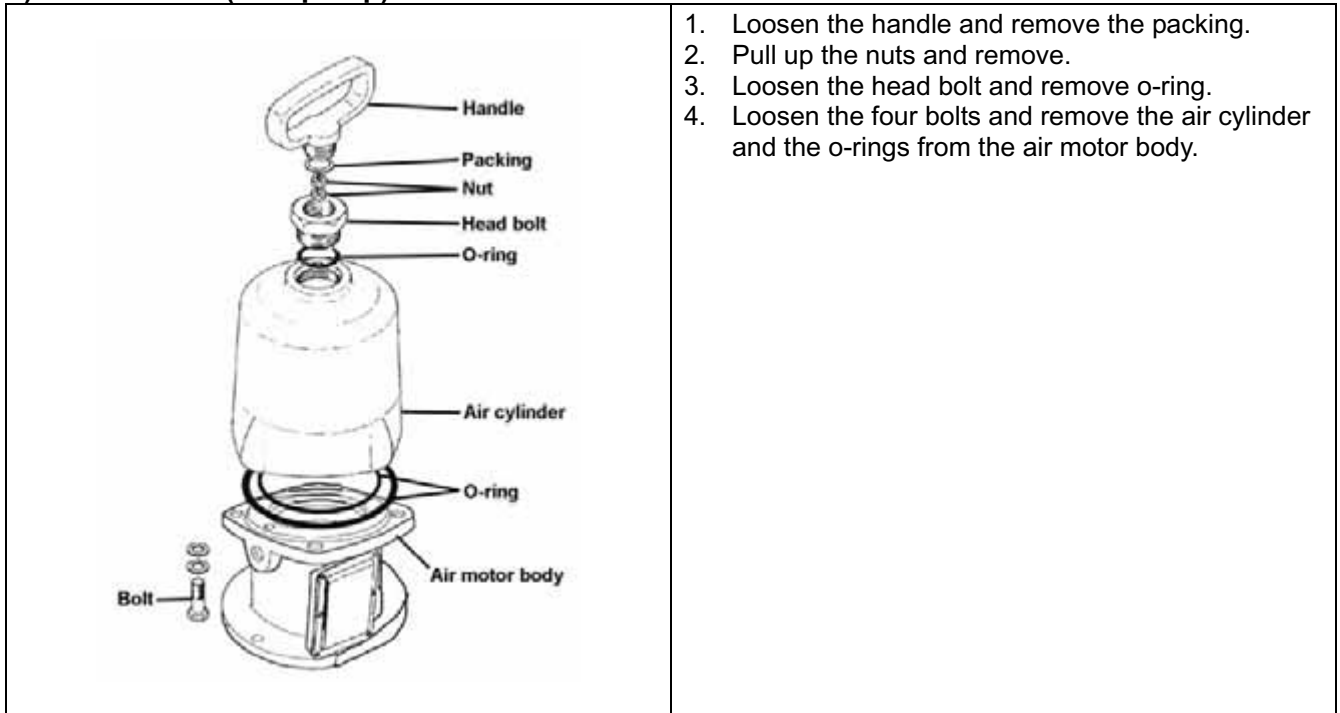

1. Loosen the handle and remove the packing.
2. Pull up the nuts and remove.
3. Loosen the head bolt and remove o-ring.
4. Loosen the four bolts and remove the air cylinder and the o-rings from the air motor body.

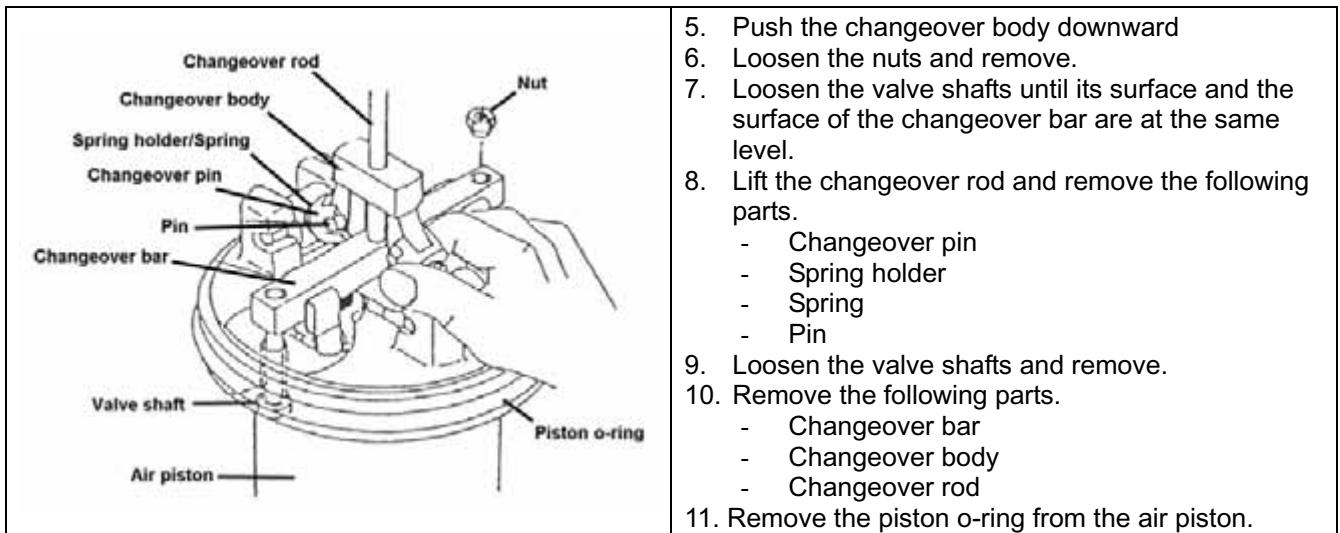

5. Push the changeover body downward
6. Loosen the nuts and remove.
7. Loosen the valve shafts until its surface and the surface of the changeover bar are at the same level.
8. Lift the changeover rod and remove the following parts.
 - Changeover pin
 - Spring holder
 - Spring
 - Pin
9. Loosen the valve shafts and remove.
10. Remove the following parts.
 - Changeover bar
 - Changeover body
 - Changeover rod
11. Remove the piston o-ring from the air piston.

9. Disassembly and Assembly

9-1-2. Suction section

IMPORTANT

1. Clean fluid passage of pump before disassembly of the suction section.
2. Do not damage or bend the rod and be sure to check that the rod is free of foreign matter. It can cause pump malfunction.
3. Do not remove the rod before loosening the wet cup. It can cause damage to the V-packing (upper).
4. Do not remove the V-packing (lower) expect during replacement.

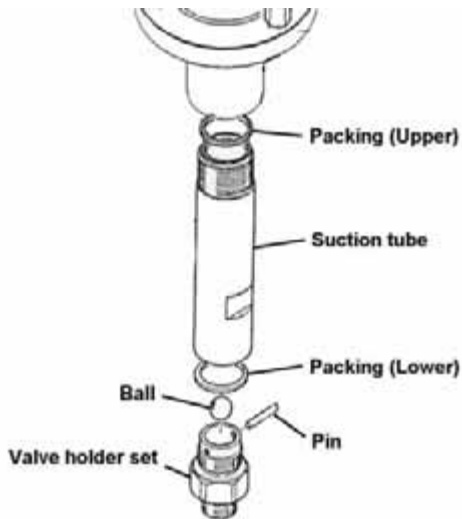

1. Loosen the suction tube and remove the packing (upper).
2. Loosen the valve adaptor and remove packing (lower).
3. Remove the pin and ball.

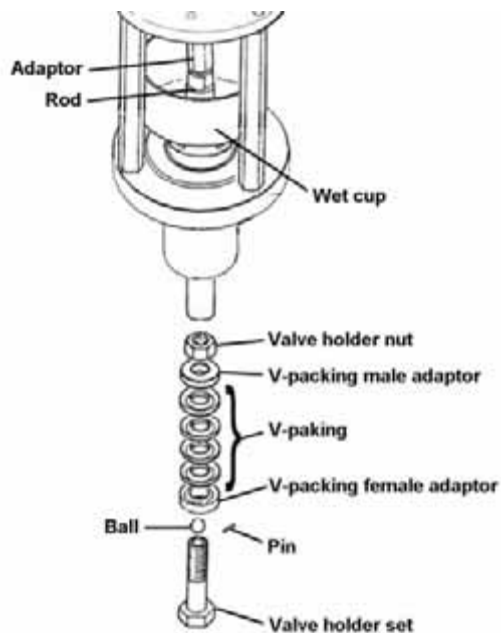

4. Loosen the wet cup.
5. Loosen the rod and remove it from the adaptor.
6. Attach wrenches to the hexagonal part of the valve holder set and the rod and remove the valve holder set from the rod.
7. Remove the pin (PP-1171CNE only) and the ball from the valve holder set.
8. Loosen the valve holder nut and remove the following parts, if necessary.
 - V-packing male adaptor
 - V-packing (lower)
 - V-packing female adaptor.

9. Disassembly and Assembly

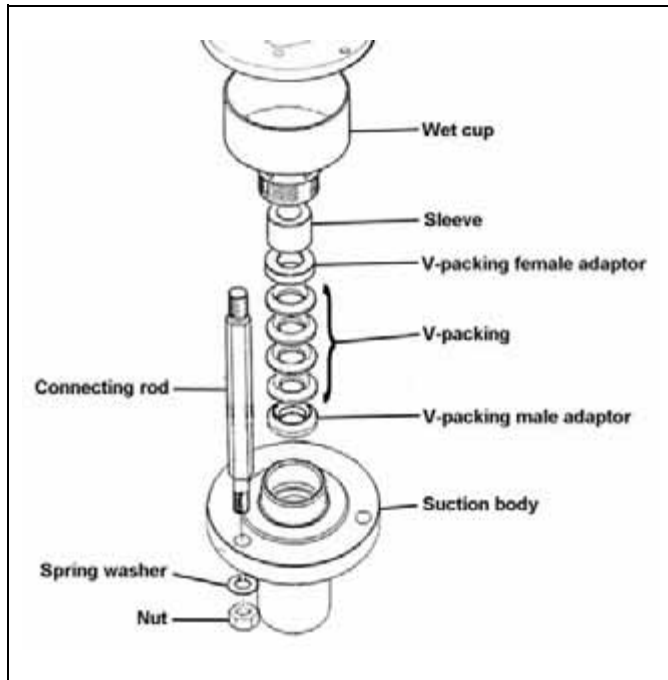

9. Loosen the three nuts and remove the spring washers.
10. Remove the suction body section from the connecting rods.
11. Loosen the wet cup and remove the following parts.
 - Sleeve (or Slide ring)
 - V-packing female adaptor
 - V-packing (upper)
 - V-packing male adaptor

9. Disassembly and Assembly

9-2. Assembly

9-2-1. Air motor section

a) PP-7131N (13:1 pump)

⚠ IMPORTANT

1. Put general-purpose grease on the moving parts, o-rings and packings inside air cylinder. Do not put grease on the parts of the seat block section.
2. Make sure that the interlock pieces are set on the slit of air motor rod.
3. Make sure that the switch block switches up when the air motor rod is at the end of the up stroke and switches down when the air motor rod is at the end of the down stroke.

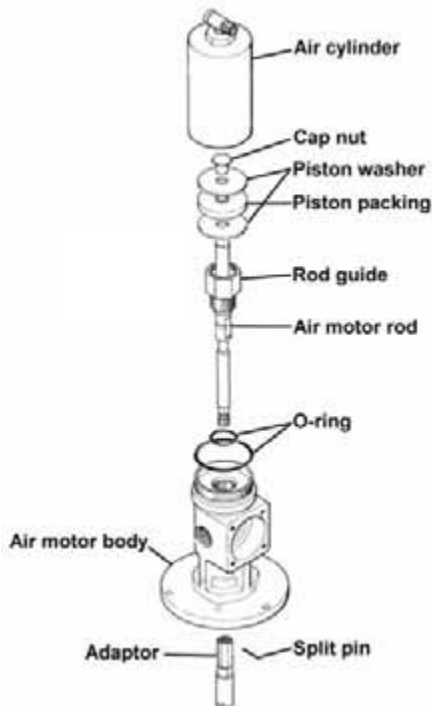
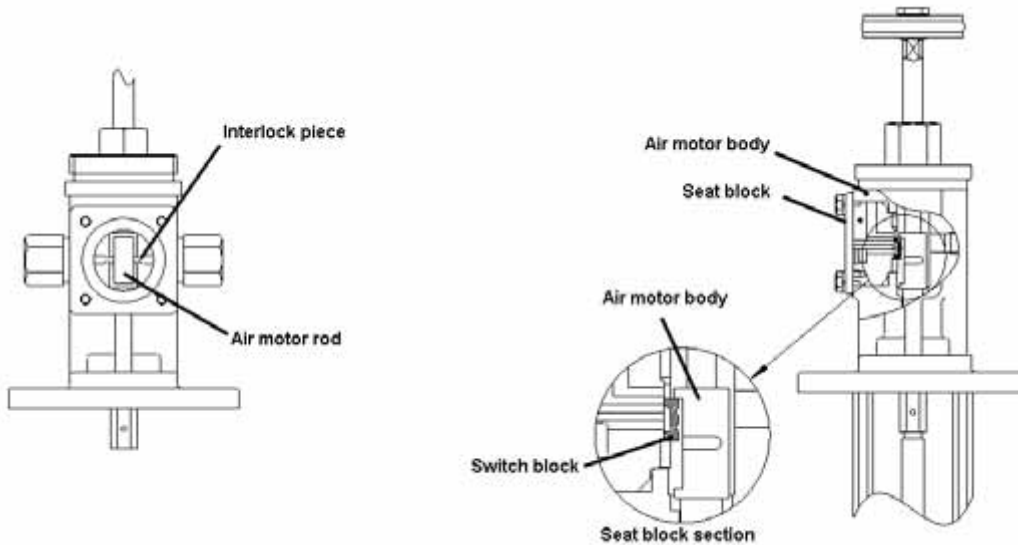

1. Place the rod guide onto the air motor rod.
2. Place the following parts on the air motor rod and tighten the cap nut.
 - O-ring
 - Piston washer
 - Piston packing
3. Place the air motor rod into the air motor body and tighten the rod guide onto the air motor body.
4. Tighten the air motor rod to the adaptor and replace the split pin.
5. Tighten the air cylinder.

9. Disassembly and Assembly

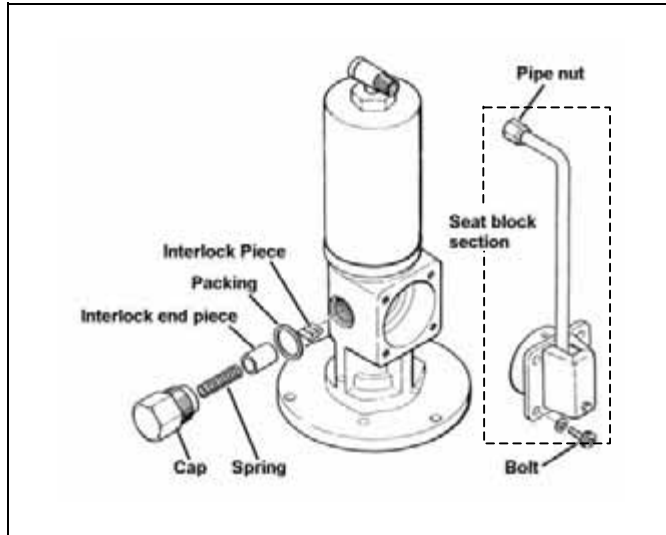

6. Place the following parts into the air motor body and tighten cap.
 - Interlock piece
 - Packing
 - Interlock end piece
 - Spring
7. Place the seat block section onto the air motor body.
8. Tighten the four bolts and the pipe nut.

b) PP-1171CNE (17:1 pump)

IMPORTANT

1. Put general-purpose grease on the moving parts, o-rings and packings inside the air cylinder.
2. When replacing the valve shaft, push the changeover bar downward and adjust the clearance between the valve shaft and the piston to 2mm (0.08inch) each sides.
3. When tightening the nuts on the changeover rod, the top surface of the nut and the changeover rod should be at the same level.

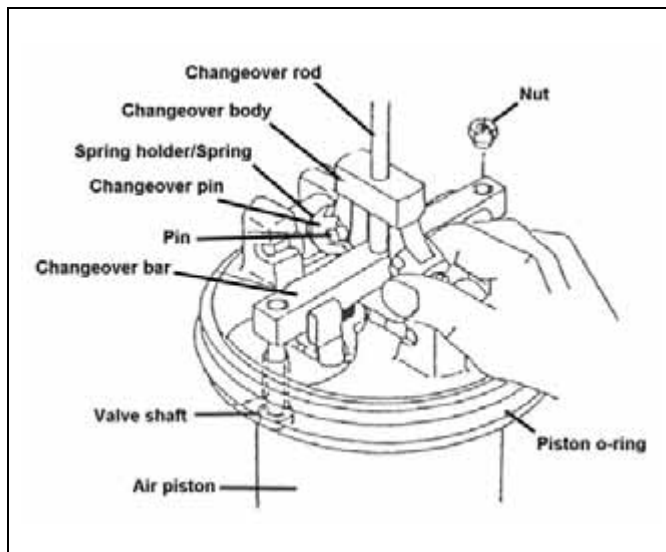
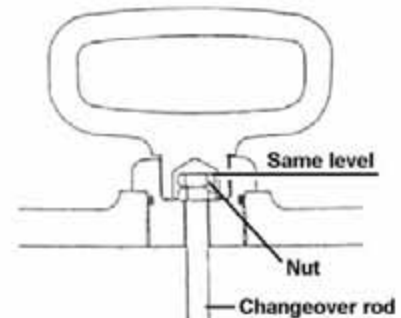
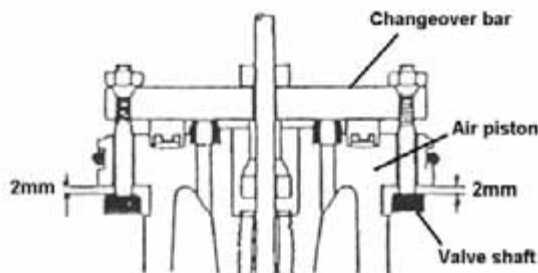

1. Place the piston o-ring on the air piston.
2. Place the following parts on the air piston.
 - Changeover bar
 - Changeover body
 - Changeover rod
3. Replace the valve shafts.
4. Replace the following parts.
 - Pin
 - Spring
 - Spring holder
 - Changeover pin
5. Push the changeover body downward, and tighten the valve shafts and the nuts.

9. Disassembly and Assembly

HINT

1. Tighten the nuts on the changeover rod before placing the air cylinder and the head bolt. It is easy to pull up the changeover rod during assembly.

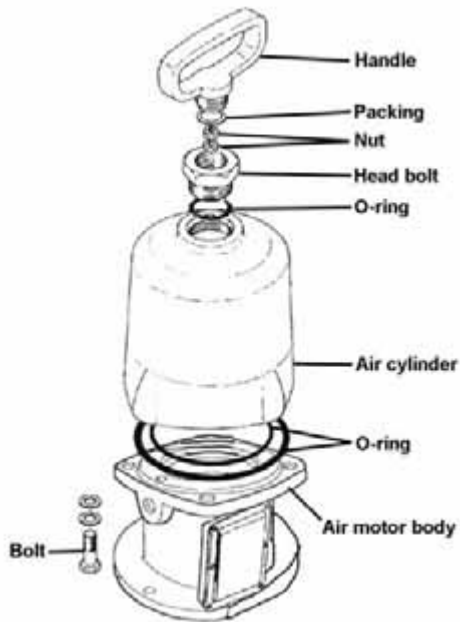
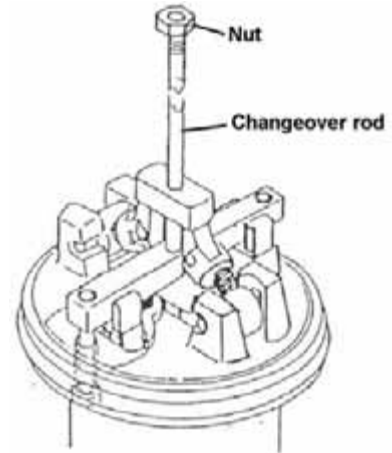

6. Place the o-rings and the air cylinder onto the air motor body and tighten the four bolts.
7. Replace the o-ring and tighten the head bolt to the air cylinder.
8. Replace the packing and tighten the handle on the head bolt.

9. Disassembly and Assembly

9-2-2. Suction section



IMPORTANT

1. Be sure to set V-packing set in the correct direction. If not, it can cause pump malfunction.
2. Always replace the four V-packings as set.
3. Do not over tighten the V-packing. It can cause damage to the V-packing during assembly or pump malfunction.
4. Always insert rod with valve holder set from the top of the suction tube. If not, it can cause damage of V-packing (lower).

HINT

1. Put general-purpose grease or lube oil on the V-packing to avoid damage during assembly.

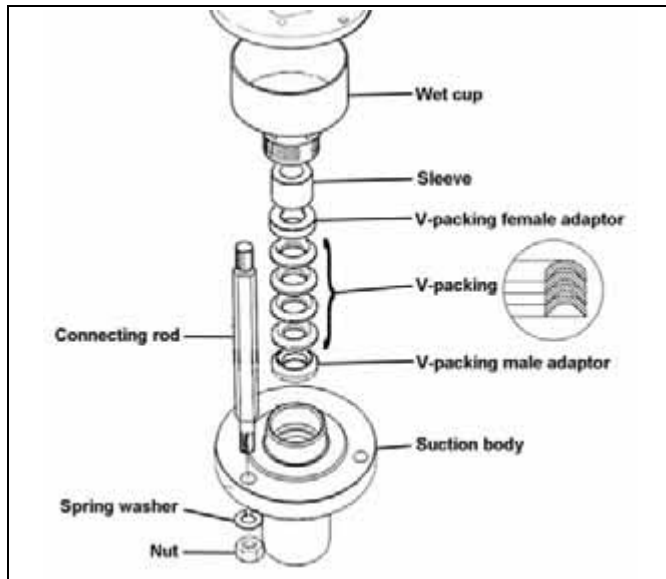

1. Place the following parts into the suction body.
 - V-packing male adaptor
 - V-packing set (upper)
 - V-packing female adaptor
 - Sleeve (or Slide ring)
2. Loosely tighten lightly the wet cup to the suction body.
3. Place the suction body section and tighten the three nuts with the washers to the connection rods.

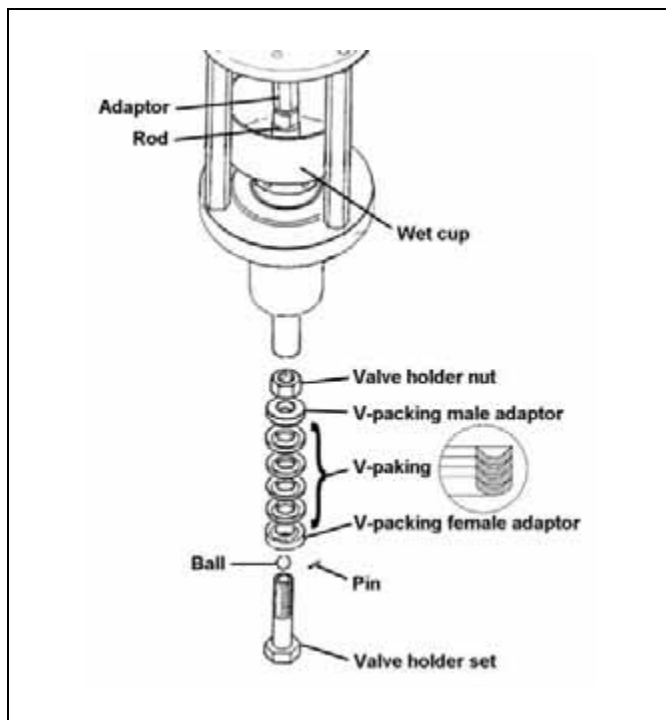

4. Place the following parts on the valve holder.
 - V-packing female adaptor
 - V-packing set (lower)
 - V-packing male adaptor
5. Tighten the valve holder nut and place the ball and the pin onto the valve holder.
6. Screw the valve holder set to the rod.
7. Insert the valve holder set with the rod into the suction tube and make sure that the rod can move up and down smoothly inside the suction tube by hand. If not, the valve holder nut is over tightened.

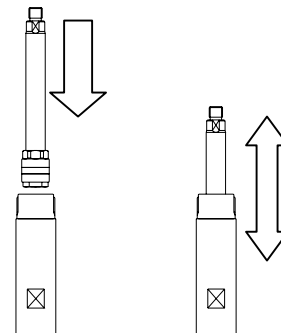

8. Tighten the rod to the adaptor.

9. Disassembly and Assembly

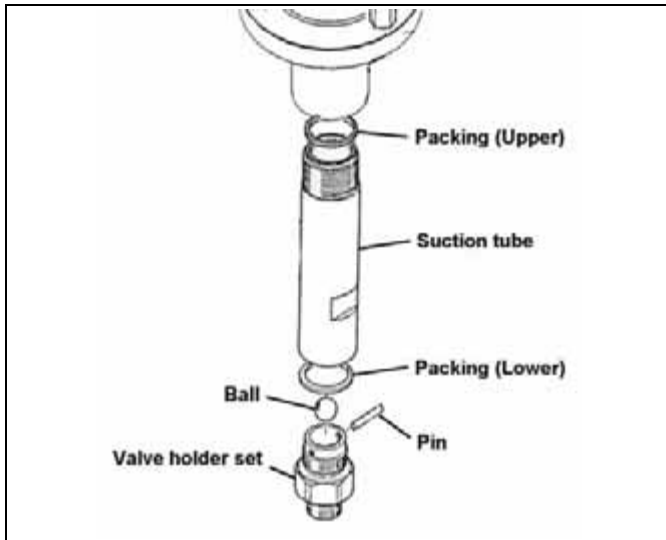

9. Place the ball and the pin onto the valve adaptor set.
10. Place the packing (lower) onto the suction tube and tighten the valve adaptor set.
11. Place the packing (upper) to the suction body and tighten the suction tube to the suction body.

IMPORTANT

1. After disassembly and assembly for cleaning, maintenance or service, run the pump to be sure that the pump operates collect according to **4-3. Checking operation** procedure on page 11.

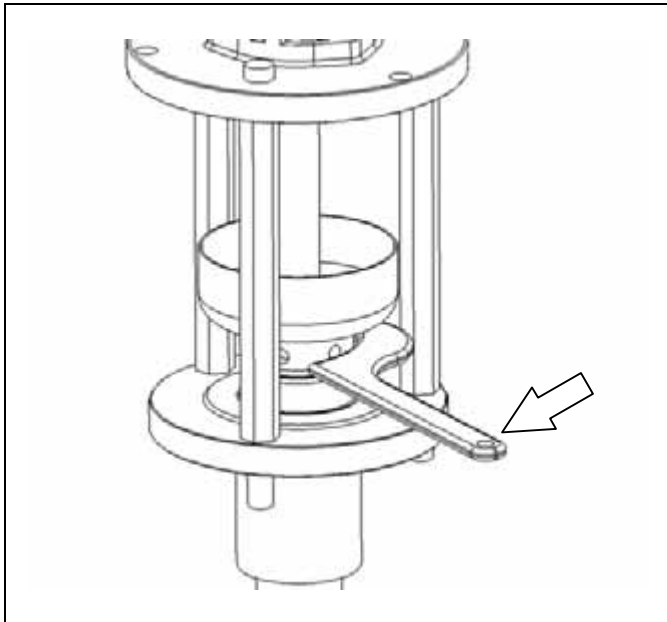

12. Tighten the wet cup.
13. Clean any grease or lube oil on the V-packings according to **5-1. Flushing** procedure on page 12.
14. Re-tighten the wet cup if cleaning fluid leaks through the wet cup during the flushing procedure.
15. Loose the wet cup if the rod does not move smoothly during pump operation.

HINT

1. Position plunger pump at the end of the down stroke to increase pump life when not in use.

10-1. Pump Unit

10-1-1. 13:1 pump unit

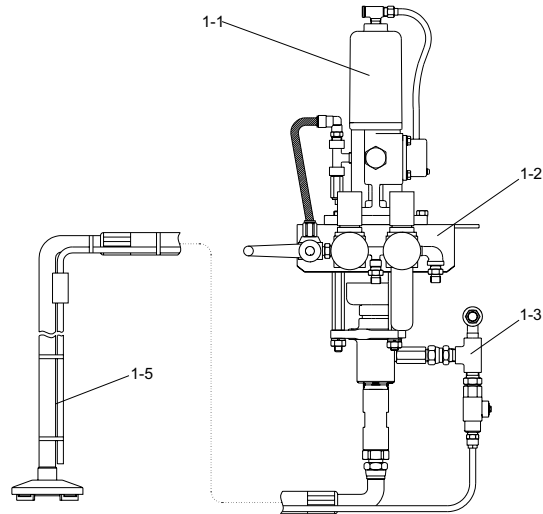

MSU-114N (Wall Mount)

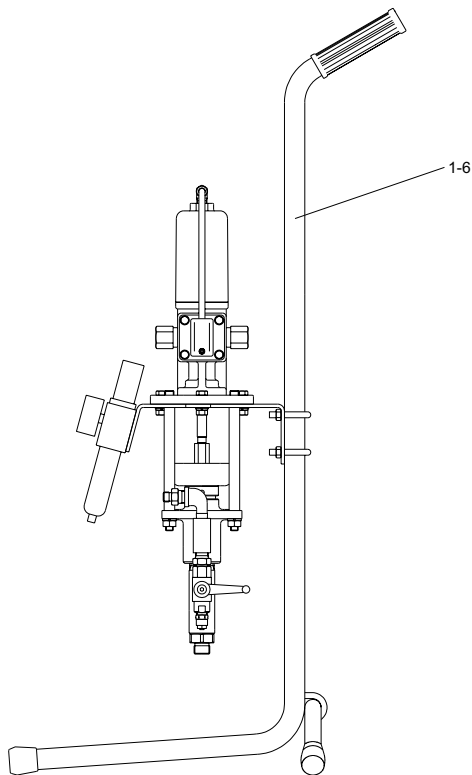

MSU-111N (Stand Mount)

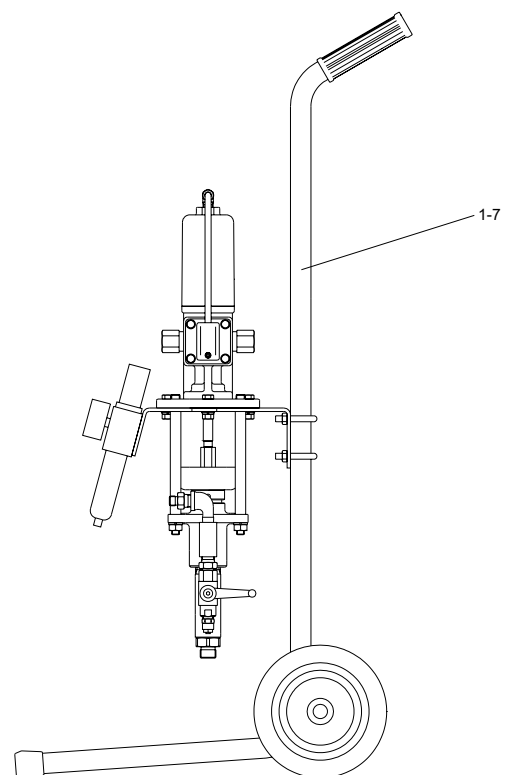

MSU-113N (Cart Mount)

No.	Description	Qty
1-1	Plunger pump, PP-7131N	1
1-2	Air regulator set	1
1-3	Circulation valve set	1
1-4	Fluid filter set (option, not shown)	1

No.	Description	Qty
1-5	Suction hose set	4
1-6	Stand set	4
1-7	Cart set	1

10. Parts List

10-1-2. 17:1 pump unit

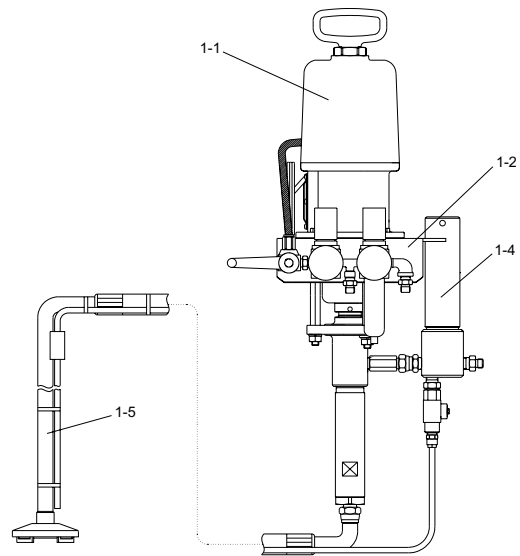

MSU-324N (Wall Mount)

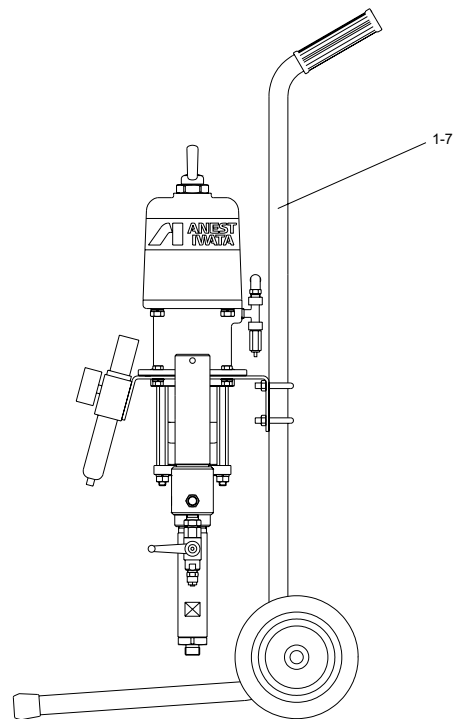

MSU-323N (Cart Mount)

No.	Description	Qty
1-1	Plunger pump, PP-1171CNE	1
1-2	Air regulator set	1
1-4	Fluid filter set	1
1-5	Suction hose set	1
1-7	Cart set	1

10-2. Plunger pump (13:1), PP-7131N

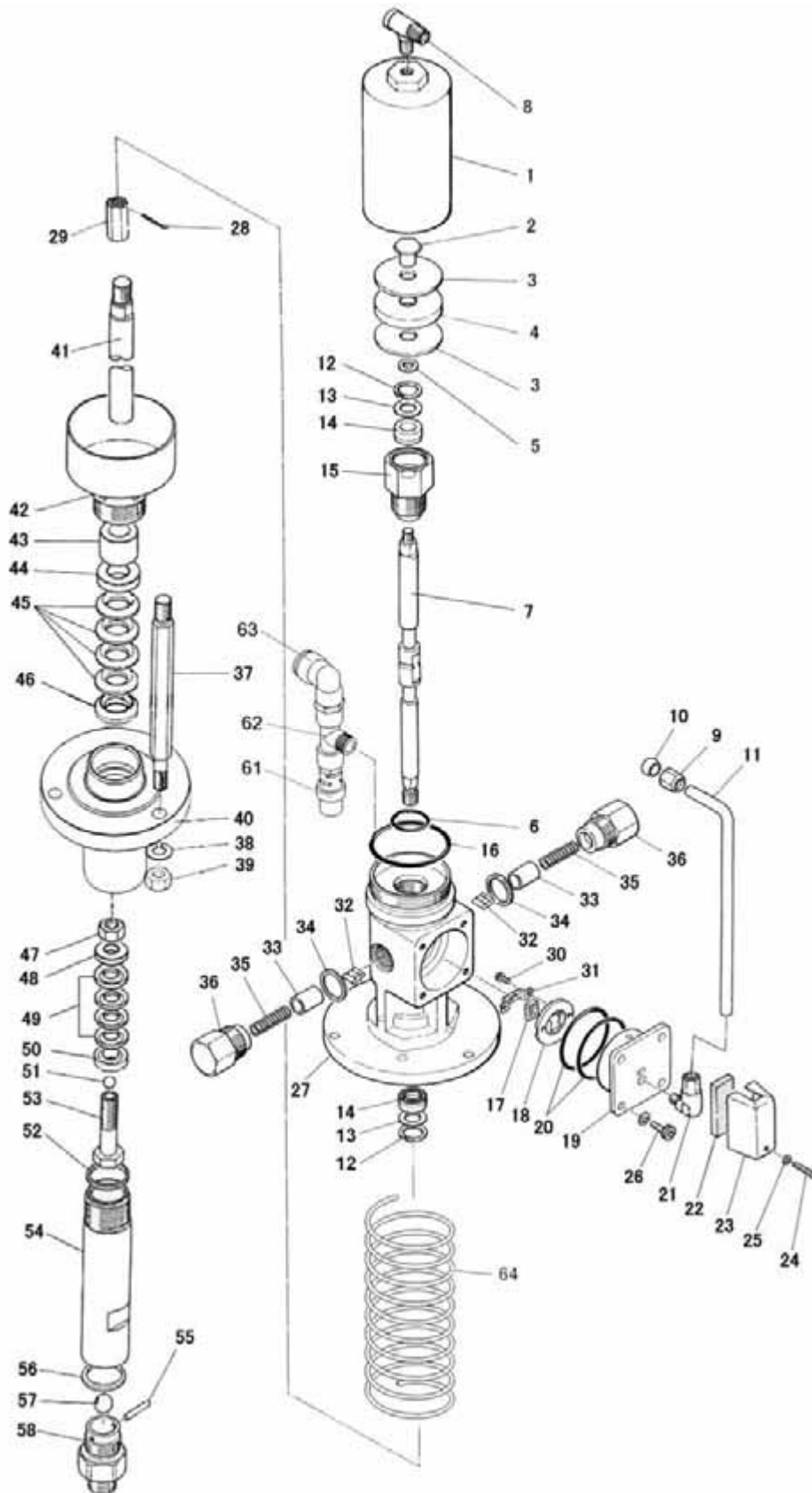

10. Parts List

No.	Description	Qty
2-1	Air cylinder	1
2-2	Cap nut	1
2-3	Piston washer	2
■ 2-4	Piston packing	1
2-5	Washer	1
■ 2-6	O-ring	1
2-7	Air motor rod	1
2-8	Air pipe joint	1
2-9	Pipe nut	1
2-10	Joint nut sleeve	1
2-11	Air pipe	1
2-12	Snap ring	2
2-13	Washer	2
2-14	Rod packing	2
2-15	Rod guide	1
■ 2-16	O-ring	1
■ 2-17	Switch block	1
2-18	Block guide plate	1
2-19	Seat block	1
■ 2-20	O-ring	2
2-21	Elbow joint	1
2-22	Exhaust muffler	1
2-23	Muffler cover	1
2-24	Screw	1
2-25	Spring washer	1
2-26	Bolt	4
2-27	Air motor body	1
2-28	Split pin	1
2-29	Adaptor	1
2-30	Screw	2
■ 2-31	Block holder	1
2-32	Interlock piece	2

No.	Description	Qty
2-33	Interlock end piece	2
■ 2-34	Packing	2
2-35	Spring	2
2-36	Cap	2
2-37	Connecting rod	3
2-38	Spring washer	3
2-39	Nut	3
2-40	Suction body	1
2-41	Rod	1
2-42	Wet cup	1
2-43	Sleeve	1
▲ 2-44	V-packing female adaptor (upper)	1
▲ 2-45	V-packing (upper)	4
▲ 2-46	V-packing male adaptor (upper)	1
2-47	Valve holder nut	1
▲ 2-48	V-packing male adaptor (lower)	1
▲ 2-49	V-packing (lower)	4
▲ 2-50	V-packing female adaptor (lower)	1
▲ 2-51	Ball (upper)	1
▲ 2-52	Packing (upper)	1
2-53	Valve holder set	1
2-54	Suction tube	1
▲ 2-55	Pin	1
▲ 2-56	Packing (lower)	1
▲ 2-57	Ball (lower)	1
2-58	Valve adaptor set	1
2-59	Fluid outlet joint (not shown)	1
2-60	Grounding wire (not shown)	1
2-61	Pop-off valve	1
2-62	Tee joint	1
2-63	Push-in elbow	1
2-64	Guard spring	1
2-65	Wet cup tool (not shown)	1

*Repair service kit of air motor section includes “■” marked parts.

*Repair service kit of suction section includes “▲” marked parts.

10-3. Plunger pump (17:1), PP-1171CNE

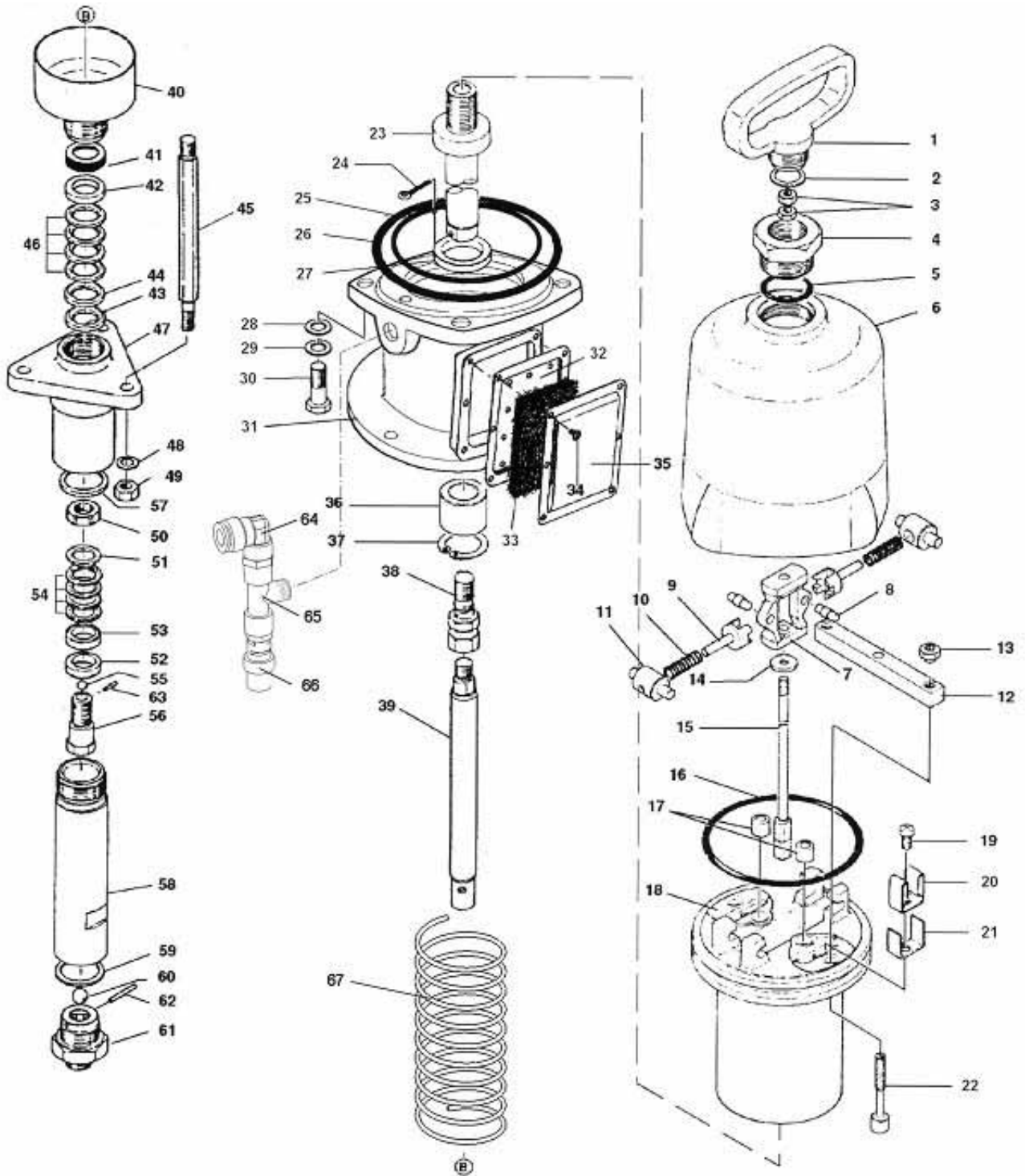

10. Parts List

No.	Description	Qty
3-1	Handle	1
■ 3-2	Packing	1
3-3	Nut	2
3-4	Head bolt	1
■ 3-5	O-ring	1
3-6	Air cylinder	1
3-7	Changeover body	1
3-8	Pin	2
3-9	Changeover pin	2
3-10	Spring	2
3-11	Spring holder	2
3-12	Changeover bar	1
3-13	Nut	2
3-14	Washer	1
3-15	Changeover rod	1
■ 3-16	Piston o-ring	1
■ 3-17	Exhaust packing	2
3-18	Air piston	1
3-19	Screw	2
3-20	Changeover bar stay	2
3-21	Reinforce plate	2
■ 3-22	Valve shaft	2
3-23	Piston rod	1
3-24	Split pin	1
■ 3-25	O-ring	1
■ 3-26	O-ring	1
3-27	Stopper	1
3-28	Washer	4
3-29	Spring washer	4
3-30	Bolt	4
3-31	Air motor body	1
3-32	Baffle plate	1
3-33	Muffler	1
3-34	Tapping screw	6
3-35	Exhaust cover	1

No.	Description	Qty
3-36	Metal	1
3-37	Stop ring	1
3-38	Adaptor	1
3-39	Rod	1
3-40	Wet cup	1
3-41	Slide ring	1
▲ 3-42	V-packing female adaptor (upper)	1
3-43	Spacer	1
▲ 3-44	V-packing male adaptor	1
3-45	Connecting rod	3
▲ 3-46	V-packing (upper)	4
3-47	Suction body	1
3-48	Spring washer	3
3-49	Nut	3
3-50	Valve holder nut	1
▲ 3-51	V-packing male adaptor (lower)	1
3-52	Spacer	1
▲ 3-53	V-packing female adaptor (lower)	1
▲ 3-54	V-packing (lower)	4
▲ 3-55	Ball (upper)	1
3-56	Valve holder set	1
▲ 3-57	Packing (upper)	1
3-58	Suction tube	1
▲ 3-59	Packing (lower)	1
▲ 3-60	Ball (lower)	1
3-61	Valve adaptor set	1
▲ 3-62	Pin	1
▲ 3-63	Pin	1
3-64	Pop-off valve	1
3-65	Tee joint	1
3-66	Push-in elbow	1
3-67	Guard spring	1
3-68	Grounding wire (not shown)	1
3-69	Fluid outlet joint (not shown)	1
3-70	Wet cup tool (not shown)	1

*Repair service kit of air motor section includes “■” marked parts.

*Repair service kit of suction section includes “▲” marked parts.

10-4. Air regulator set

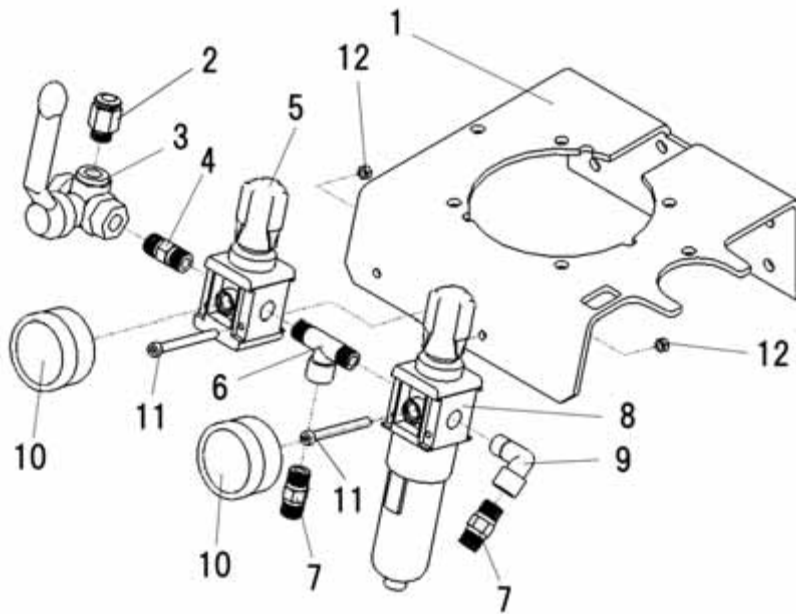

No.	Description	Qty
4-1	Pump base	1
4-2	Push-in joint	1
4-3	3-way ball valve	1
4-4	Nipple	1
4-5	Air regulator	1
4-6	Tee joint	2
4-7	Nipple	1
4-8	Air filter regulator	1
4-9	Elbow joint	2
4-10	Pressure gauge	2
4-11	Bolt	2
4-12	Nut	2

10-5. Circulation valve set for 13:1 pump unit

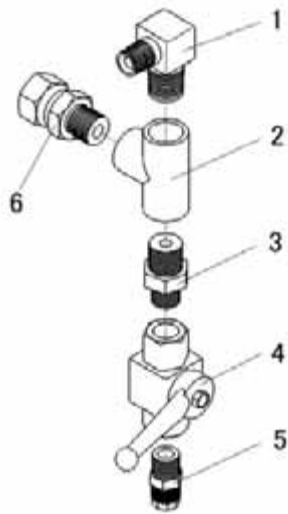

No.	Description	Qty
5-1	Elbow joint	1
5-2	Tee joint	1
5-3	Nipple	2
5-4	2-way ball valve	1
5-5	Hose joint	1
5-6	Swivel joint	1

10. Parts List

10-6. Fluid filter set for 13:1 pump unit (option)

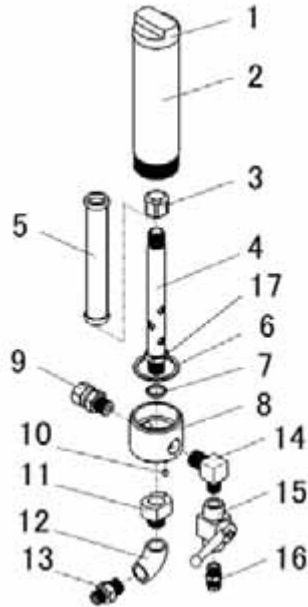

No.	Description	Qty
6-1	Filter plug	1
6-2	Cylinder	1
6-3	Cap nut	1
6-4	Filter bolt	1
6-5	Filter 100mesh	1
6-6	Packing	1
6-7	Packing	1
6-8	Filter body	1
6-9	Swivel joint	1
6-10	Spring pin	1
6-11	Filter adaptor	1
6-12	Elbow joint	1
6-13	Nipple	1
6-14	Elbow joint	1
6-15	2-way ball valve	1
6-16	Hose joint	1
6-17	Locking nut	1

10-7. Fluid filter set, TF-8N for 17:1 pump unit

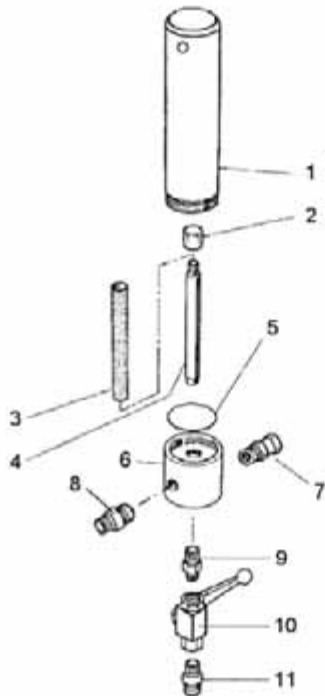

No.	Description	Qty
7-1	Cylinder	1
7-2	Cap nut	1
7-3	Filter 100mesh	1
7-4	Filter bolt	1
7-5	O-ring	1
7-6	Filter body	1
7-7	Swivel joint	1
7-8	Nipple	1
7-9	Nipple	1
7-10	2-way ball valve	1
7-11	Hose joint	1

10-8. Suction hose set

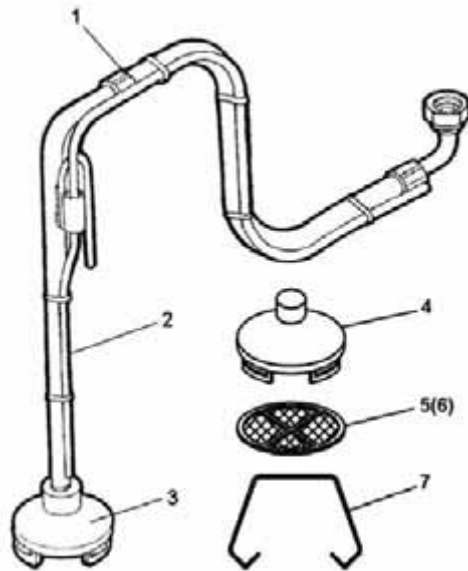

No.	Description	Qty
8-1	Suction Hose	1
8-2	Circulation Tube	1
8-3	Filter Set	1
8-4	Filter Cover	1
8-5	Filter 50mesh	1
8-6	Filter 100mesh (Option)	1
8-7	Filter Spring	1

11. Spray Gun Nozzle Tip Chart

Orifice Size inch (mm)	Fluid Output oz/min (mL/min)	Pattern Width: inch (mm)				
		5 - 7 (13 - 18)	7 - 9 (18 - 23)	9 - 11 (23 - 28)	11 - 13 (28 - 33)	13 - 15 (33 - 38)
0.008 (0.19)	6 (180)	NT1502CMU				
0.008 (0.21)	8 (240)		NT2002CMU			
0.009 (0.23)	9 (270)	NT1503CMU				
0.011 (0.28)	12 (360)		NT2003CMU			
0.011 (0.29)	15 (450)			NT2503CMU		
0.012 (0.31)	18 (540)				NT3003CMU	
0.013 (0.33)	21 (630)					NT3503CMU
0.014 (0.35)	16 (480)		NT2004CMU			
0.014 (0.36)	20 (600)			NT2504CMU		
0.014 (0.34)	24 (720)				NT3004CMU	
0.016 (0.41)	28 (840)					NT3504CMU
0.016 (0.40)	20 (600)		NT2005CMU			
0.018 (0.45)	25 (750)			NT2505CMU		
0.016 (0.42)	30 (900)				NT3005CMU	
0.019 (0.48)	36 (1050)					NT3505CMU
0.019 (0.49)	37 (1080)				NT3006CMU	
0.021 (0.54)	43 (1260)					NT3506CMU

Test fluid: Melamine paint

Viscosity: 65cps (20sec/NK-2, 22sec/Ford#4, 29sec/Zahn#2)

Fluid pressure: 725psi (5.0MPa, 0.5bar)

Spray distance: 9.8 inch (250mm).



ANEST IWATA USA, Inc.
9920 Windisch Road
West Chester OH 45069-3804
(513) 755-3100 FAX: (513) 755-088E
Toll Free: (800) 440-0282
www.anestiwata.com