



GB

# ***DOUBLE DIAPHRAGM PUMP***

- DDP 90 D***
- DPS 90 1 D***
- DPS 90 2 D***
- DPS 90 3 D***
- DPS 90 4 D***
- DPS 90 36 D***
- DDP 90 C WB***
- DPS 90 3 C WB***





## ***Dear Customer,***

*We thank you for the preference you gave us and we are glad to count you among our customers. We hope the use of this equipment will satisfy you and your staff.*

*We have first of all designed our products by focusing not only on our experience, but also on the latest mechanical innovations. The products have then been manufactured with first-rate materials and techniques and tested by considering your requirements.*

*We thank you once again and remember that all our technical services are at your disposal for any present and future requirement.*

## **ANEST IWATA EUROPE TORINO - ITALY**

---

**The company** ANEST IWATA EUROPE Srl mission is to supply all their product and spray painting equipment users and distributors with the STATE-OF-THE-ART of technology and with continuous innovations, to obtain the best finish at the lowest cost.

Our product range must offer the perfect balance between the energy use and its consequences, to help to safeguard and improve the environment.

All Anest Iwata Europe Srl staff members use their knowledge and skills to provide their customers with an excellent service to satisfy them with high quality and reliability and with continuous innovation.

Our activities, as those of many other companies, are in compliance with several European Directives (Safety and Environment) and International Standards (ISO - Quality and Environment).

As to SAFETY, the standards our products refer to are the CE 89/382 Directive and subsequent; all our items of this type have the CE marking, are supplied with a Technical File which can be consulted on request and are accompanied by a use manual (standardized by the European standards EN 292) available in different languages.

There are also some specific safety standards, that is EN 1953 standard as to spray guns, and **prEN 12621** as to pressure pumping circuits. These standards can be consulted or bought at **UNI**.

As to **QUALITY** standards (**ISO 9000**), ANEST IWATA EUROPE is provided with the ISO 9002 certification. Our company philosophy gives all our partners, distributors and users any possible information, which is very useful for our product use, for the environment safeguard and for the operators' safety.



# CONTENTS

<b>USE OF THE MANUAL</b> .....	4
<b>SYMBOLS USED</b> .....	4
<b>INFORMATIVE LETTER</b> .....	5
<b>WARRANTY</b> .....	7
<b>1. TRANSPORT AND HANDLING</b> .....	8
1.1 Transport .....	8
1.2 Transport with cardboard packaging .....	8
1.3 Handling .....	9
1.4 Temporary storage .....	9
<b>2. PRODUCT IDENTIFICATION</b> .....	10
2.1 Plate data .....	10
2.2 The different models .....	11
2.3 Technical specifications .....	12
2.4 Safety systems .....	17
2.5 Workable products .....	18
<b>3. OPERATION</b> .....	19
3.1 Operation description .....	19
<b>4. INSTALLATION AND STARTING</b> .....	20
4.1 Check on the purchased product .....	20
4.2 Conditions for installation .....	20
4.3 Installation of DDP 90 D and DDP 90 CE WB base models .....	20
4.4 Installation of DPS 90 1 D , DPS 90 2 D, DPS 90 3 D, DPS 90 4 D, DPS 90 36 D .....	21
<b>5. USE</b> .....	27
5.1 Use .....	27
5.2 Safety rules during use .....	27
5.3 Clothes .....	27
5.4 Prewash .....	28
5.5 Starting .....	28
5.6 Daily interruptions .....	30
5.7 Wrong and dangerous uses .....	31
5.8 Pressure release process .....	32
<b>6. MAINTENANCE AND INSPECTION</b> .....	33
6.1 General notes .....	33
6.2 Safety rules during maintenance .....	33
6.3 Recommended programmed operations .....	33
6.4 Diaphragm pump disassembly from its base support .....	33
6.5 Double pneumatic valve disassembly .....	34
6.6 Diaphragm disassembly .....	35
6.7 Diaphragm reassembly .....	36
6.8 Delivery and suction valve disassembly .....	36
6.9 Delivery and suction valve reassembly .....	36
6.10 PR 3E fluid pressure regulator disassembly and maintenance .....	37
6.11 PR 3E fluid pressure regulator reassembly .....	38
6.12 PR 5 fluid pressure regulator disassembly and maintenance .....	40
6.13 PR 5 fluid pressure regulator reassembly .....	42
6.14 Paint filter maintenance .....	43
<b>7. TROUBLESHOOTING</b> .....	44
7.1 DDP 90 CE double diaphragm pump .....	44
7.2 PR 3E paint pressure regulator .....	48
7.3 PR 5 paint pressure regulator .....	49
<b>8. SECTIONS WITH SPARE PART LIST</b> .....	50
8.1 DDP 90 D / DDP 90 CE WB double diaphragm pump .....	50
8.2 PR 3E / PR 3E WB paint pressure regulator .....	52
8.3 PR 5 paint pressure regulator .....	53
<b>9. ACCESSORIES</b> .....	54
9.1 Air adjusting unit .....	54
9.2 Dip tube with filter .....	54
9.3 Supports .....	55
9.4 Hopper unit .....	55
9.5 Wye .....	55
<b>10. DISMANTLING</b> .....	56



## Use of the manual

The use and maintenance manual is the document accompanying the equipment from its manufacture till its dismantling. Therefore, it is an integral part of the equipment.

The manual must be read before starting ANY ACTIVITY involving the equipment including its handling.

For a better consultation the instruction manual is divided into the following sections:

### SECTION 1

Transport, packaging, handling and check on the purchased product.

### SECTION 2

Description of the equipment and of its field of application.

It also describes all the technical features of the equipment.

This information can be compared to that of an illustrative leaflet.

### SECTION 3

Equipment installation.

### SECTION 4

Description of the controls to use the equipment.

### SECTION 5

Ordinary and extraordinary maintenance.

### ENCLOSURES

Exploded view and list of components.

## Symbols used

The operations which can be dangerous if they are not carried out correctly, are indicated with the symbol:



The operations requiring a qualified or specialised staff, to avoid any danger, are indicated with the symbol:



It is advisable to train the staff who have to use the equipment and to check if everything is understood and carried out.



## Other symbols



Index of the use and maintenance manual



Transport



Description of the equipment



Installation



Ordinary use



Wiring and hydraulic diagrams



Dismantling

## Informative

This use and maintenance manual is an integral part of the equipment and it must be easily available to the staff in charge of its use and maintenance.

The user and the maintenance man must know the content of this manual. All the descriptions and pictures contained in this manual are not binding.

Although the main features of this equipment are not subject to change, the manufacturing Company reserves itself the right to change those components, details and accessories it deems necessary to improve the machine or to meet manufacturing or commercial requirements, at any time and without updating this manual immediately.



### WARNING

TO ENSURE THE GOOD WORKING OF THE EQUIPMENT AND OF ITS SAFETY DEVICES, THE PUMP MUST BE INSTALLED BY A QUALIFIED STAFF.



### WARNING

ALL RIGHTS ARE RESERVED. THE REPRODUCTION OF ANY PART OF THIS MANUAL, IN ANY FORM, IS STRICTLY FORBIDDEN WITHOUT PRIOR WRITTEN AUTHORIZATION OF THE MANUFACTURING COMPANY.

THE CONTENT OF THIS MANUAL CAN BE MODIFIED WITHOUT NOTICE. GREAT CARE HAS BEEN TAKEN IN COLLECTING AND CHECKING THE DOCUMENTATION CONTAINED IN THIS MANUAL TO MAKE IT AS COMPLETE AND COMPREHENSIBLE AS POSSIBLE.



**WARNING**

THIS USE AND MAINTENANCE MANUAL DOES NOT MAKE UP FOR ANY DESIGN INADEQUACY.

In case of breakdown or malfunction, apply to the CUSTOMER CARE SERVICE.

**CUSTOMER SERVICE**



**ANEST IWATA EUROPE s.r.l.**  
**C.so Vigevano, 46 - 10155 Torino**  
**Telephone +39 011.24.80.868**  
**Telefax +39 011.85.19.44**  
**E-mail: [info@anest-iwataeu.com](mailto:info@anest-iwataeu.com)**



**WARNING**

THE ORIGINAL CONFIGURATION OF THE EQUIPMENT MUST NOT BE CHANGED AT ALL.

On receiving the equipment check that:

**The supply corresponds to the order specifications.**

**In case of non-compliance, inform immediately our Technical Services.**



## Warranty

All **ANEST IWATA S.r.l.** products have a one-year guarantee from the invoice date, unless otherwise stated in writing. The warranty covers all manufacturing faults and material defects. Any spare part replacement or repair operations are covered only if they are carried out by our technicians at our servicing shops.

The faulty parts must be sent **CARRIAGE PAID**.  
Once the components have been repaired, they will be sent **CARRIAGE FORWARD** to the customer.

The warranty covers no intervention of our technicians during installation or dismantling operations. If for practical purposes one of our technicians is sent on site, a charge will be made for the time plus extra for travelling and expenses.

Our warranty does not cover direct or indirect damage to people or property caused by our equipment. It covers no repair operations carried out by the customer or by a third party, either.

### **THE WARRANTY DOES NOT COVER:**

- Damage or breakdown caused by improper use or assembly.
- Damage or breakdown caused by the use of spare parts that are different from the original or recommended ones.
- Damage or breakdown caused by a bad preservation.
- Components subject to wear (described in the spare part list).

### **WARRANTY FORFEITURE:**

- In case of delayed payment or other contractual defaults.
- Whenever changes or repairs are carried out on our equipment without prior authorization.
- Whenever the serial number is damaged or removed.
- When the damage is caused by improper use or functioning, or if the equipment falls, is bumped or by other causes not due to the normal working conditions.
- Whenever the unit is disassembled, tampered with or repaired without the authorization of **ANEST IWATA S.r.l.**

All repair interventions carried out under warranty do not interrupt its duration.

All disputes will be settled in the court of justice of Turin.



## 1.1 Transport

To transport the equipment only the systems described below can be used. In any case make sure that the transport and lifting device can bear the weight of the equipment with its packaging.



**WARNING**  
ALWAYS KEEP THE PACKAGING IN VERTICAL POSITION.



**WARNING**  
IT IS ADVISABLE THAT THE STAFF IN CHARGE OF HANDLING THE EQUIPMENT WEAR PROTECTIVE GLOVES AND SAFETY SHOES.



**WARNING**  
WHILE LIFTING OR HANDLING THE EQUIPMENT OR ANY OF ITS COMPONENTS CLEAR THE WORKING AREA. LEAVE ALSO A SUFFICIENT SAFETY AREA AROUND THE EQUIPMENT TO AVOID DAMAGING PEOPLE OR OBJECTS WHICH COULD BE THERE.

## 1.2 Transport with cardboard packaging

The equipment is put inside a cardboard packaging and wrapped with some shockproof material.

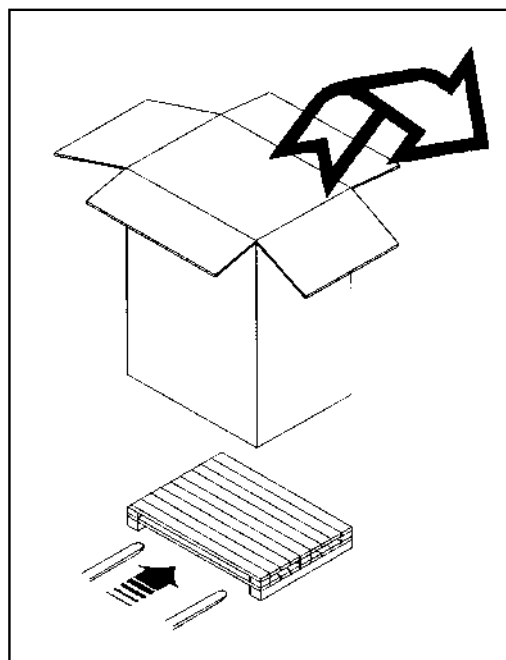





### 1.3 Handling

To handle the cardboard packaging use a trolley.



**WARNING**

FOLLOW THE INSTRUCTIONS ON THE PACKAGING BEFORE HANDLING AND OPENING IT.

HANDLING BY MEANS OF HANDLE

HANDLING BY MEANS OF TROLLEY

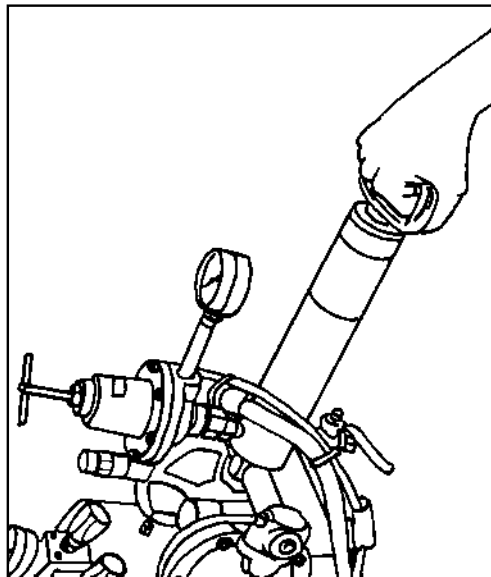

### 1.4 Temporary storage

During transport and storage make sure the temperatures between 0 and 40° C are not exceeded.

In case of storage, make sure the equipment is not put in places with an excessive humidity.



### 2.1 Plate data

The manufacturer's identification plate is applied on the diaphragm pump (see picture below).

It must not be removed at all, even if the equipment is resold. For any communication with the manufacturer always mention the serial number written on the plate itself.

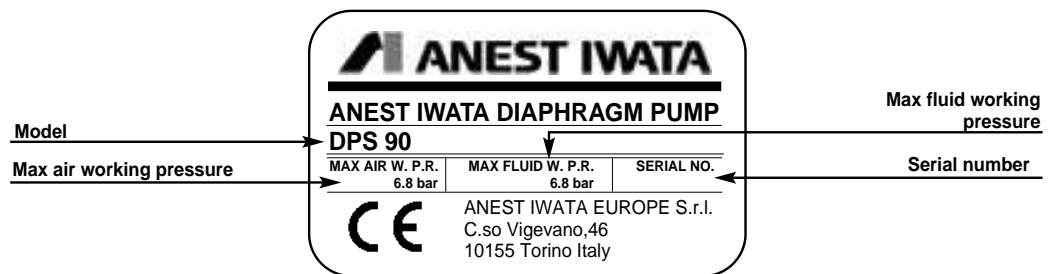



## 2.2 The different models

The following pump models are available:

### SOLVENT-BASED PAINT MODELS

**Base Model: Pump casing type DDP 90 D**

#### SIPHON MODELS:

- DPS 90 1 D:** Pump type DDP 90 D mounted on a stand with PR 3E (or PR5) paint pressure regulator, 2 air pressure reducers (for pump and gun), dip tube with filter, paint filter unit, fluid recirculation, 2 safety devices (1 overpressure valve, 1 three-way valve).
- DPS 90 2 D:** Pump type DDP 90 D mounted on a 20 l. tank with PR 3E (or PR5) paint pressure regulator, paint filter unit, fluid recirculation, 2 safety devices (1 overpressure valve, 1 three-way valve), 2 air pressure reducers (for pump and gun).
- DPS 90 3 D:** Trailer-mounted pump type DDP 90 D with PR 3E (or PR5) paint pressure regulator, air pressure reducing filter (for gun), air pressure reducer (for pump), dip tube with filter, paint filter unit, fluid recirculation, 2 safety devices (1 overpressure valve, 1 three-way valve).
- DPS 90 4 D:** Pump type DDP 90 D on wall mounting bracket with PR 3E (or PR5) paint pressure regulator, air pressure reducing filter (for gun), air pressure reducer (for pump), dip tube with filter, paint filter unit, fluid recirculation, 2 safety devices (1 overpressure valve, 1 three-way valve).

#### GRAVITY MODELS:

- DPS 90 36 D:** Trailer-mounted pump type DDP 90 D with plastic hopper (6 litres with 50 mesh filter), PR 3E (or PR5) paint pressure regulator, air pressure reducing filter (for gun), air pressure reducer (for pump), paint filter unit, fluid recirculation, 2 safety devices (1 overpressure valve, 1 three-way valve).

### WATER-BASED PAINT MODELS

**Base Model: Pump casing type DDP 90 CE WB**

#### SIPHON MODEL:

- DPS 90 3 C WB:** Trailer-mounted pump type DDP 90 CE WB with PR 3E WB paint pressure regulator, air pressure reducing filter (for gun), air pressure reducer (for pump), dip tube with filter, paint filter unit, fluid recirculation, 2 safety devices (1 overpressure valve, 1 three-way valve).



## 2.3 Technical specifications

### DDP 90 D

DIAPHRAGM PUMP MODEL	DDP 90 D	DDP 90 CE WB
Dimensions	235 x 155 x 210 mm	
Weight	3,400 kg	
Air inlet	G 1/4"	
Entrata materiale	G 1/2"	
Fluid inlet	G 3/8"	
Fluid delivery filter	100 mesh	
Max air working pressure	7.0 bar	
Min air working pressure	2.0 bar	
Compression ratio	1:1	
Max fluid working pressure	7.0 bar	
Max fluid viscosity	85 sec/Ford #4 (100 sec./NK-2)	
Delivery per cycle	50 cc/per cycle	
Max No. of cycles per minute	200 cycles per min.	
Max delivery	10 litres per min. (water)	
Working temperature	from 5 to 40 °C	
Compressor (required power by each pump)	from 0.4 to 0.75 kW	





**DPS 90 1 D**  
**DPS 90 2 D**

MODELS	DPS 90 1 D	DPS 90 2 D
Dimensions	500x430x1015 mm	360x335x760 mm
Weight	11,900 Kg	11,120 Kg
Air inlet	G 1/4"	
Fluid outlet	G 3/8"	
Fluid suction filter	50 mesh	
Fluid delivery filter	100 mesh	
Max air working pressure	7.0 bar	
Min air working pressure	2.0 bar	
Max fluid working pressure	(See PR 3E or PR5)	
Max fluid viscosity	85 sec/Ford # 4 (100 sec/NK-2)	
Max fluid delivery	(See PR 3E or PR5)	
Working temperature	from 5 to 40 °C	
Noise level	75.3 dB(A)*	
Compressor (required power)	from 0.4 to 0.75 kW (only for pump) from 2.2 to 3.7 kW (for pump and gun)	
Pressure regulator	PR 3E (or PR5)	

**\*This noise level has been measured in compliance with Machinery Directive 89/392 and with ISO 3744 standards.**

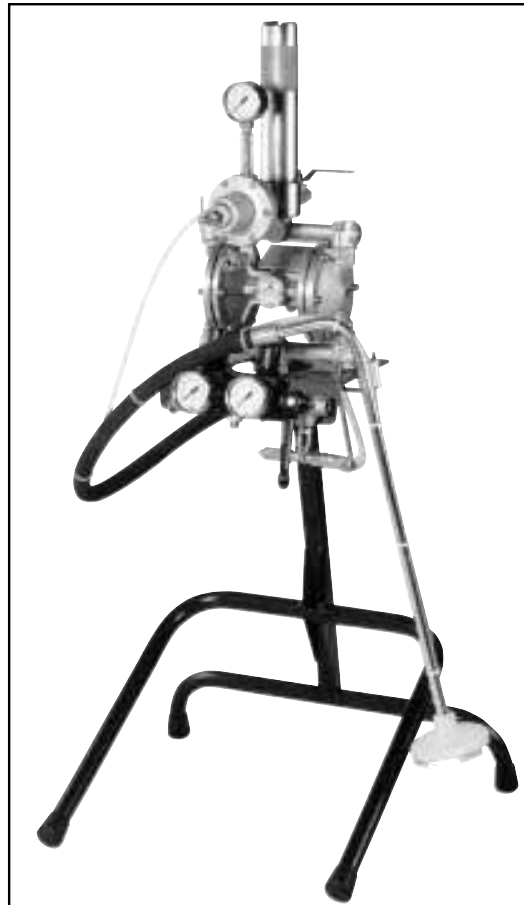



**DPS 90 3 D  
DPS 90 3 C WB**

MODELS	DPS 90 3 D	DPS 90 3 C WB
Dimensions	500x500x1055 mm	500x500x1055 mm
Weight	15,900 Kg	15,900 Kg
Air inlet		G 1/4"
Fluid outlet		G 3/8"
Fluid suction filter		50 mesh
Fluid delivery filter		100 mesh
Max air working pressure		7.0 bar
Min air working pressure		2.0 bar
Max fluid working pressure		(See PR 3E or PR5)
Max fluid viscosity		85 sec/Ford # 4 (100 sec/NK-2)
Max fluid delivery		(See PR 3E or PR5)
Working temperature		from 5 to 40 °C
Noise level		75.3 dB(A)*
Compressor (required power)		from 0.4 to 0.75 kW (only for pump) from 2.2 to 3.7 kW (for pump and gun)
Pressure regulator	PR 3E or PR5	PR 3E WB

**\*This noise level has been measured in compliance with Machinery Directive 89/392 and with ISO 3744 standards.**





## DPS 90 4 D

MODELS	DPS 90 4 D
Dimensions	360x260x600 mm
Weight	11,400 Kg
Air inlet	G 1/4"
Fluid outlet	G 3/8"
Fluid suction filter	50 mesh
Fluid delivery filter	100 mesh
Max air working pressure	7.0 bar
Min air working pressure	2.0 bar
Max fluid working pressure	(See PR 3E or PR5)
Max fluid viscosity	85 sec/Ford # 4 (100 sec/NK-2)
Max fluid delivery	(See PR 3E or PR5)
Working temperature	from 5 to 40 °C
Noise level	75.3 dB(A)*
Compressor (required power)	from 0.4 to 0.75 kW (only for pump) from 2.2 to 3.7 kW (for pump and gun)
Pressure regulator	PR 3E or PR5

**\*This noise level has been measured in compliance with Machinery Directive 89/392 and with ISO 3744 standards.**

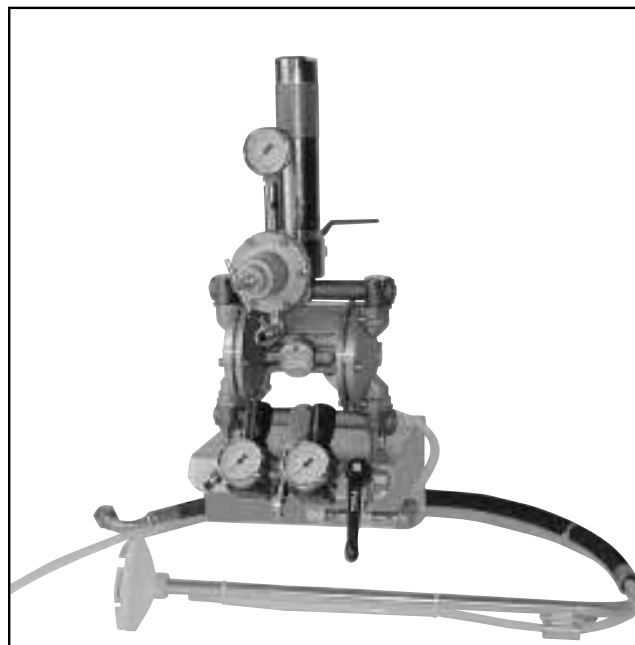



**DPS 90 36 D**

MODELS	DPS 90 36 D
Dimensions	535x500x1055 mm
Weight	16,600 Kg
Air inlet	G 1/4"
Fluid outlet	G 3/8"
Fluid suction filter	50 mesh
Fluid delivery filter	100 mesh
Max air working pressure	7.0 bar
Min air working pressure	2.0 bar
Max fluid working pressure	(See PR 3E or PR5)
Max fluid viscosity	85 sec/Ford # 4 (100 sec/NK-2)
Max fluid delivery	(See PR 3E or PR5)
Working temperature	from 5 to 40 °C
Noise level	75.3 dB(A)*
Compressor (required power)	from 0.4 to 0.75 kW (only for pump) from 2.2 to 3.7 kW (for pump and gun)
Pressure regulator	PR 3E or PR5

\*This noise level has been measured in compliance with Machinery Directive 89/392 and with ISO 3744 standards.







## 2.4 Safety systems

Several safety systems have been conceived during the diaphragm pump design and manufacture to safeguard the operator, in compliance with pr EN 12621 Directive about paint.

### **SAFETY VALVE**

A 8 bar calibrated safety valve is installed to ensure the pump working pressure does not exceed the limits inside the feeding circuit.

If the calibration pressure is exceeded, the valve opens by releasing the excess of air.



### **WARNING**

DO NOT REMOVE THE VALVE PLASTIC PROTECTION. ANY TAMPERING WITH COULD BE DANGEROUS FOR THE OPERATOR AND COMPROMISE THE EQUIPMENT GOOD WORKING.

### **THREE-WAY VALVE**

In case of anomalies during working, turn 90° the three-way valve lever. In this way the air supply will be interrupted and the residual pressure inside the pump will be released.





## Safety pictograms

Some pictograms can be found on the pump with the safety warnings to follow by anyone who is going to use it.



### WARNING

THE MANUFACTURING COMPANY IS NOT TO BE HELD RESPONSIBLE FOR DAMAGE OR ACCIDENTS TO PEOPLE OR THINGS COMING FROM THE NON-COMPLIANCE WITH THE PRESCRIBED RULES. THE RESPONSIBILITY RESTS ENTIRELY WITH THE OPERATOR HIMSELF.

<b>WARNING</b>		E 1-Rev. 0
<b>READ:</b>	Read the enclosed INSTRUCTION MANUAL and all documents before start up operation.	
<b>WARNINGS:</b>		
- INSTALLATION:	Install the pump vertically, and fix it securely.	
- CONNECTIONS:	Tighten all connections securely before start up operation.	
<b>DANGER:</b>		
- FORBIDDEN FLUIDS:	Never use HALOGENATED HYDROCARBON FLUID such as Trichloroethane, Methylene Chloride or a fluids containing such chemical contents.	
- INJURY:	Never touch driving parts during pump operations.	
- GROUNDING:	Secure the grounding before start up operation.	
- PRESSURE RELIEF:	Relieve the air body in the unit before any servicing.	

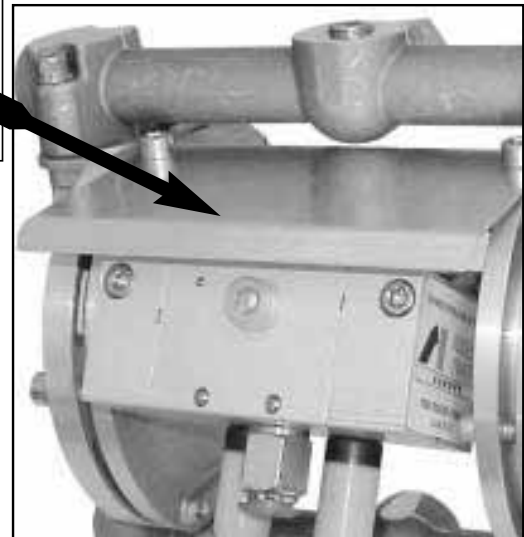

## 2.5 Workable products

All DPS 90 diaphragm pumps are conceived to paint ferrous material in general, wood and plastic. The products that can be delivered are: water-based and solvent-based paints with a maximum viscosity of 85 sec/Ford # 4 (100 sec/NK-2).

To use the pump with special products ask for the manufacturer's approval. Moreover, the pump technical features will have to be adapted to the special product working.

The Company ANEST IWATA is not to be held responsible for any accident due to the pump use by an UNAUTHORIZED and non qualified staff using it for purposes that are different from the above mentioned ones.

### WARNING

#### DO NOT USE:

- ANY HALOGENATED HYDROCARBON SOLVENTS, SUCH AS TRICHLOROETHANE, METHYLENE CHLORIDE OR SOMETHING LIKE THAT;
- ANY INFLAMMABLE OR VERY TOXIC PRODUCTS SUCH AS PETROL, KEROSENE, INFLAMMABLE SOLVENTS OR COMBUSTIBLE GASES;
- ANY HERBICIDE OR PESTICIDE
- ANY RADIOACTIVE FLUID





### 3. DDP 90 CE PUMP OPERATION

#### 3.1 Operation description

Based on a simple manufacture, the operation consists in two diaphragm movement, which are both fixed at the end of a rod, pressurizing and sending the paint.

The compressed air enters the air chamber from side A in picture 1. The diaphragm is moved to the left, by pushing the paint.

At the same time, the diaphragm on the opposite end (side B) moves to the left by sucking the paint.

When the rod is completely on the left, the double pneumatic valve reverses the operations.

The compressed air enters the air chamber from side B in picture 2. The diaphragm is moved to the right, by pushing the paint.

At the same time, the diaphragm on side A end sucks the paint.

The pump repeats the above-mentioned suction and delivery movements. The result is a steady and pulsation-free material flow.

The main feature is the action of two pneumatic valves: the first one is a power valve feeding the pump, and the other one a control valve always ensuring the movement.

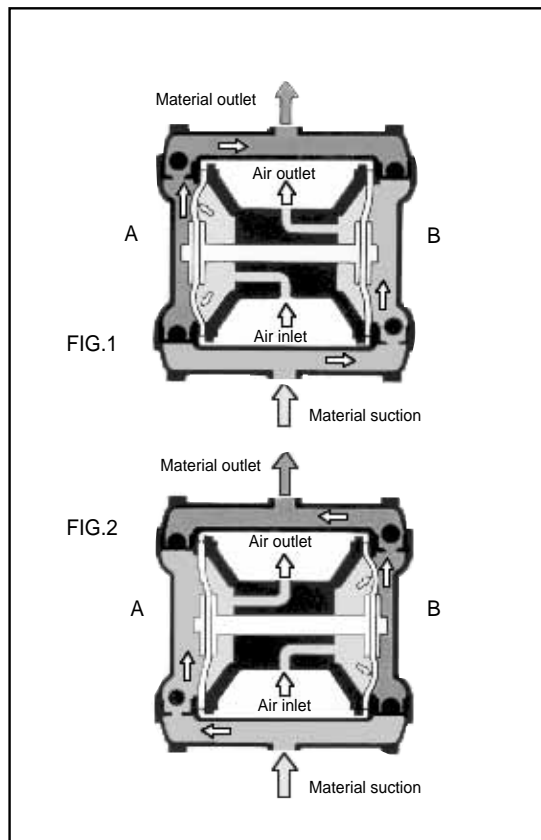



### 4.1 Check on the purchased product

Before using the pump, make sure it has not been damaged during transport or storage. Also check that all standard components are inside the packaging.

### 4.2 Conditions for installation

The equipment must be installed by a **specialized and authorized staff**. In any case, follow the instructions below.

Painting **must preferably take place inside a suitable spray booth equipped with suction device**.

Do not use the unit if the suction device is off.



#### WARNING

IF PAINTING IS CARRIED OUT OUTSIDE THE SPRAY BOOTH, ALWAYS OPERATE IN A PLACE WITH A RIGHT VENTILATION TO AVOID CONCENTRATING INFLAMMABLE VAPOURS COMING FROM SOLVENTS OR PAINTS.

### 4.3 Installation of DDP 90 D and DDP 90 CE WB base models:

- Place the pump on a stable support, to avoid movements during use.
- The distance between the pump and the fluid (height of suction) must be as short as possible. However, it can vary according to viscosity and required delivery.
- Connect the air supply to the pump supply connection (see C on page 30).
- The suction pipe must have an inside diameter of at least 1/2" or slightly higher.
- To install the pump use two M8x12 screws by means of the special holes on the intake manifold. Do not fasten the pump with any other system.
- Earth the free end of the ground cable directly.



#### WARNING

THE FLUIDS USED AND THE REQUIREMENTS MUST BE IN COMPLIANCE WITH SECTION 2.5 (WORKABLE PRODUCTS) AND WITH SECTION 5.0 (USE).



#### WARNING

- CONSULT THE LOCAL CODE FOR DETAILED INSTRUCTIONS RELATIVE TO GROUND CONNECTIONS IN THE WORK AREA AND TO THE TYPE OF SYSTEM USED.

- THE GROUND CABLE (INCLUDED IN THE SUPPLY) MUST HAVE A MINIMUM SECTION EQUAL TO 1.5 mm<sup>2</sup>.

- ONE END OF THE CABLE MUST BE EARTHEN WHILE THE OTHER MUST BE CONNECTED TO THE LATERAL LID OF THE DIAPHRAGM PUMP.

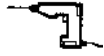

#### 4.4

#### Installation of models:

**DPS 90 1 D - DPS 90 2 D - DPS 90 3 D - DPS 90 4 D - DPS 90 6 D**

Because of shipment reasons the pump is delivered overturned. Before using it

1. Support the pump and unscrew the two M8x12 screws by means of a 6 mm Allen wrench.

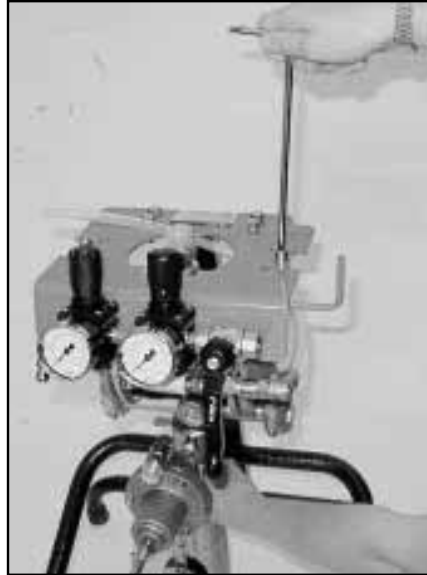

2. Place the pump in the right direction and screw again the M8x12 screws.





3. By means of a spanner connect the PR3 E or PR5 material pressure regulator to the swivel connector (1- 22 on page 51) on the paint filter.



4. Connect the feed pipe to the pump supply connection (1-38 on page 51).

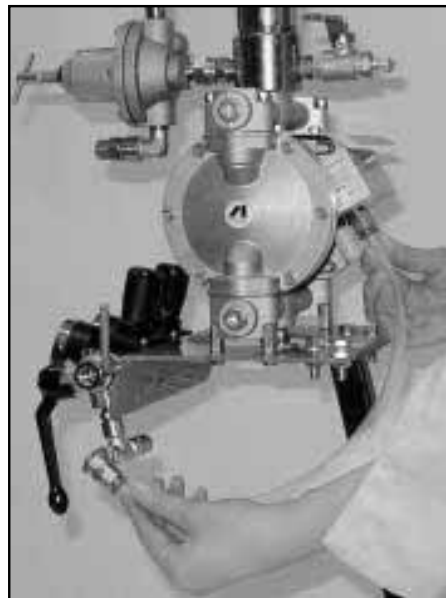

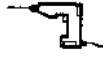

5. Connect the suction pipe to the suction connector (1-47 on page 51).



6. Connect the recirculation pipe to the two-way valve for paint recirculation (B on page 30).

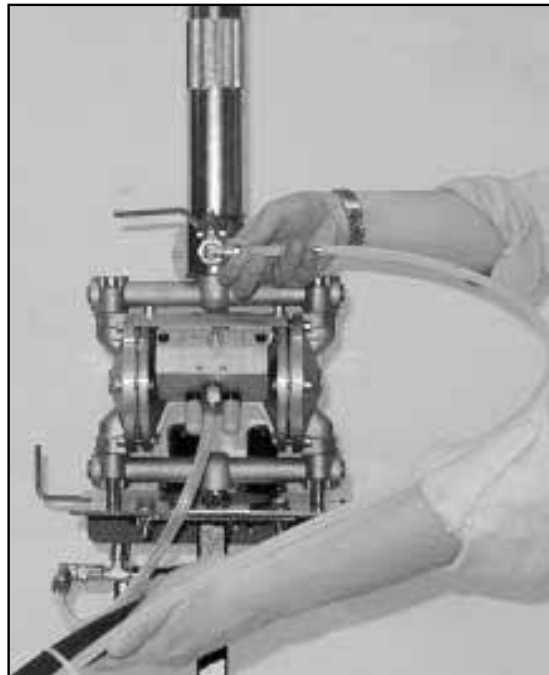



7. For gravity models, fasten the hopper by means of the two M6x10 screws.

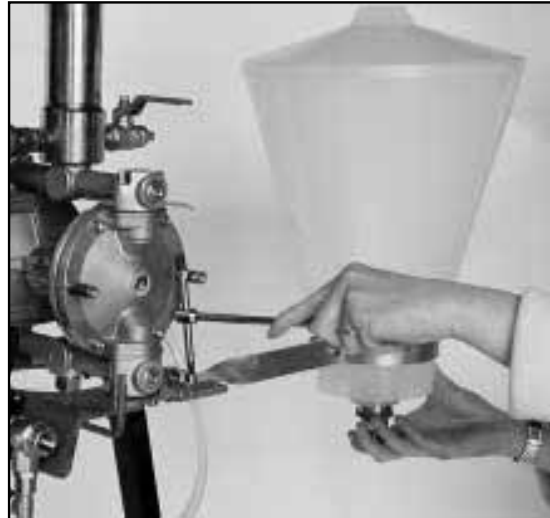

8. Connect the pipe connecting the hopper to the pump. Connect the recirculation pipe to the two-way valve for paint recirculation.



9. For the models with wall mounting bracket the pump is already in the right position. After fastening the pump, just connect the suction pipe.
10. The model with tank requires no installation operation.



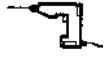

11. Make sure the PR 3E (or PR5) regulator is not under pressure, otherwise turn the adjusting screw counterclockwise till the pressure is completely released.



12. Connect the air and fluid pipes to the fluid outlet connector and to the air connector (Pump and Gun).

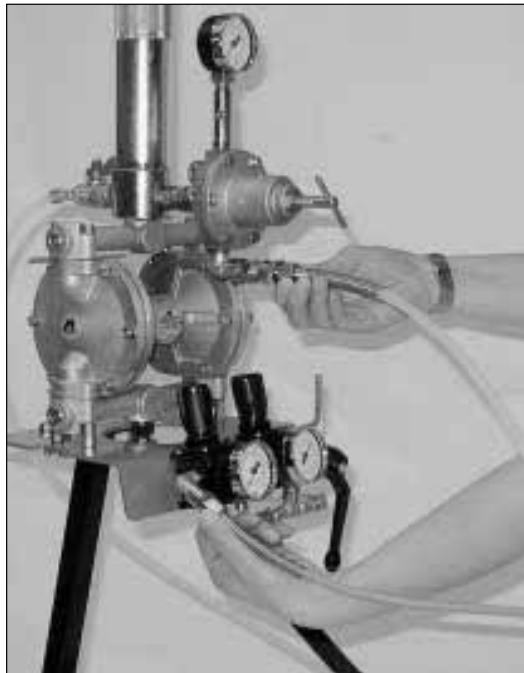



13. Connect the air supply coming from the compressor to the inlet connector.

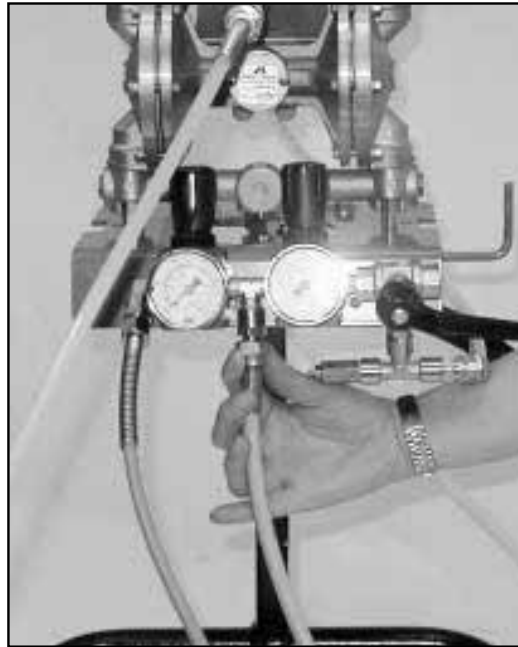

14. Fasten the pump to the ground by means of the bracket welded on the trailer or on the stand.

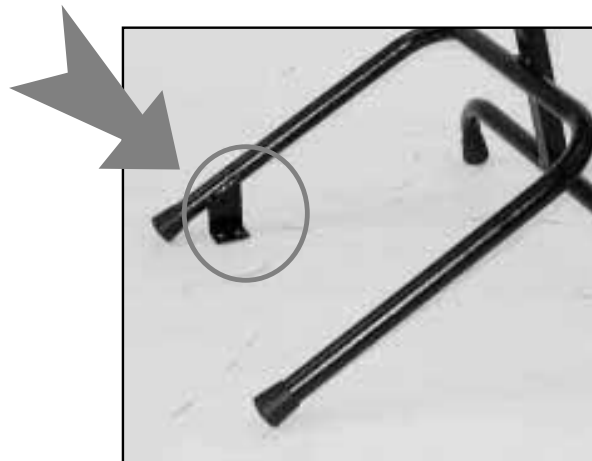



## 5. USE

### 5.1 Use

This section describes the diaphragm pump use in compliance with the safety standards in force. Read this section carefully.

### 5.2 Safety rules during use

**TO USE** the diaphragm pump **COMPLY WITH** the safety precautions and rules described below.

The manufacturing company declines all responsibility if the operator does not comply with them. It is not to be held responsible for any carelessness during the pump use, either.



If the system is used improperly, it could be broken by causing serious damage.

Use the diaphragm pump for professional purposes only.

Do not change the system; use only Anest Iwata original spare parts.

Check the system daily: repair or replace immediately all worn or damaged parts.

Never exceed the maximum working pressure: 7 bar (700 kpa).

**IT IS FORBIDDEN** to use the equipment for purposes that are different from the ones it is destined to which are described in the use and maintenance manual. If in doubt, apply to your Anest Iwata reseller.

Use paints and solvents compatible with the system parts they come in touch with. Refer to the paint and solvent features mentioned by the manufacturer.

Wear the protective clothes described in section 5.3.

Comply with all the local standards on electric safety and fire risks.

### 5.3 Clothes

Wear some protective gloves and goggles, an oxygen mask and some ear protections during working. Always follow the laws in force (Ex. LAW 626/94).

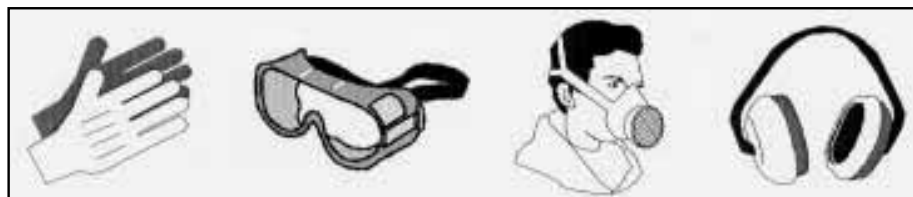



## 5.4 Prewash

1. Make sure the pump is installed correctly (see section 4.3).
2. Soak the dip tube into the washing liquid, or fill the hopper or the tank according to the model used.
3. Put the three-way valve in the right position.
4. Adjust the inlet pressure between 2,0 and 7,0 bar.
5. Open gradually the two-way valve for paint recirculation (B on page 30). The washing liquid will have to circulate through the dip tube recirculation pipe.
  - If the DPS 90 2 D model is used, the washing liquid will circulate through the paint handling system (JET STREAM).
  - The DPS 90 36 D model recirculation pipe is directly connected to the hopper.
6. Close the two-way valve for paint recirculation and adjust the fluid pressure by means of PR 3E (or PR5) regulator (Recommended pressure for washing 3.0 bar)
7. Press the gun trigger (or supply the automatic gun opening control with some air), without spraying air and let the washing fluid circulate for some minutes.
8. Make sure the washing has been done and then discharge the pump residual liquid and stop it.



### WARNING

THE PUMP MUST BE WASHED BEFORE USING IT FOR THE FIRST TIME, IF IT IS NOT USED FOR A LONG TIME AND AFTER ANY COLOUR CHANGE.

## 5.5 Starting

**Before beginning working, start the pump by following the instructions below:**

1. For all models with suction pipe, dip it into the product tank to be pumped.  
For the model with hopper, fill it with the product to be pumped.  
For the models on tank, fill the product tank to be pumped.
2. Open the two-way valve for paint recirculation (Pos. B on page 30).
3. Lift and turn gradually the pressure reducer knob (Pos. H on page 30). Adjust it at a pressure slightly higher than 2,0 bar, to enable the pump to release the air.
4. Close the two-way valve for paint recirculation (Pos. B on page 30) and release the air through the gun, too.
5. Increase the pressure of the reducer connected to the pump (Recommended pressure about 5,0 bar).



6. Adjust the PR 3E (or PR5) paint pressure regulator as required (from 0 to 3,0 bar for PR3 E, and from 0 to 6.0 bar for PR5).
7. Adjust the spraying air by means of the reducer (Pos. F on page 30) and test the gun on a panel before using it.



### **PRECAUTIONS**

- a) Use the gun under pressure.
- b) When the paint level inside the tank decreases, the pump can suck some air. Increase the paint level.
- c) Do not drag the pump by pulling it by the pipes.



### **PRECAUTIONS: EMERGENCY STOP**

When the pump must be stopped because of the following reasons:

- a) The material does not stop coming out of the gun.
- b) Fluid discharge through the connectors or the damaged pipe. **CLOSE THE THREE-WAY VALVE**  A



## 5.6 Daily interruptions

### 1. When the pump is stopped:

- The air supply must not be disconnected if the interruption is short.
- If the interruption is long, turn the three-way valve **A** discharge the air from the circuit and open the recirculation valve **B** , to release the residual fluid pressure.

### 2. When the pump is stopped at the end of the working day:

- Wash the fluid passages.
- Remove the dip tube filter and the filter inside the paint filter and clean it.

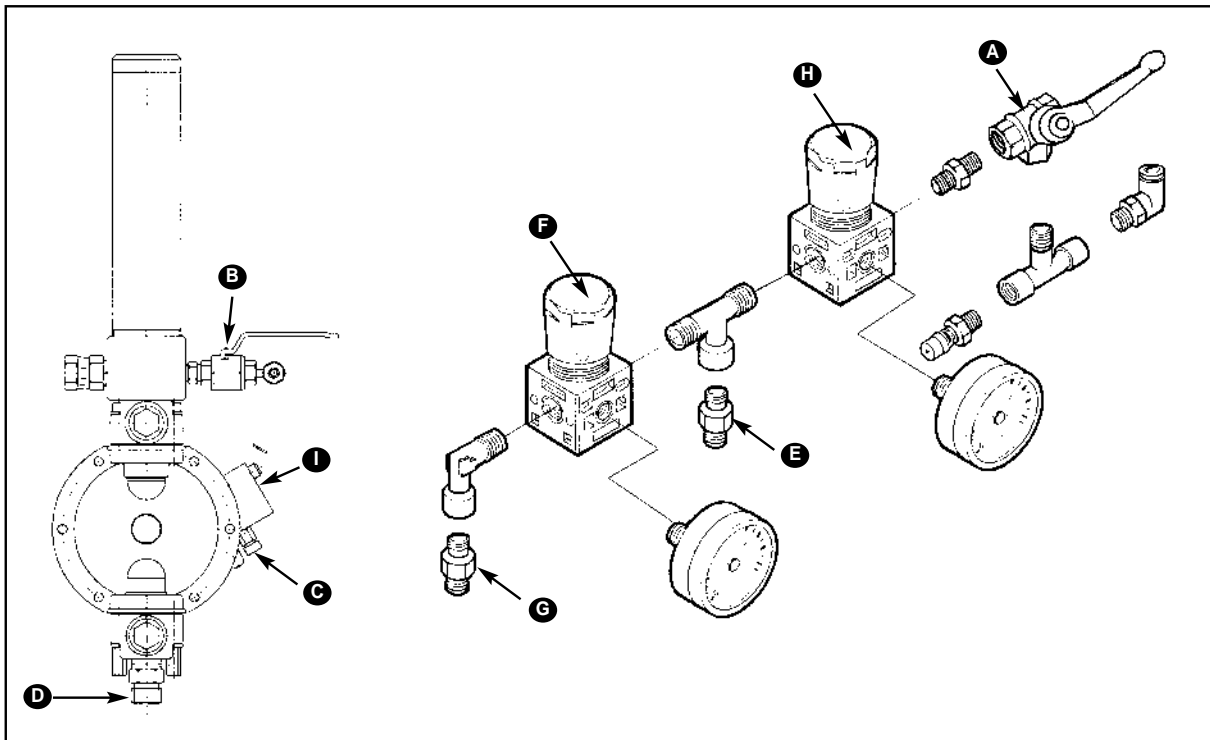

- A) Three-way valve
- B) Two-way valve for paint recirculation
- C) Supply connection
- D) Suction connector
- E) Feeder line connector
- F) Gun air pressure reducer
- G) Air connector to gun
- H) Pump air pressure reducer
- I) Double pneumatic valve



## 5.7

### Wrong and dangerous uses



**A wrong earthing, an insufficient ventilation, a naked flame or a spark can cause a fire or an explosion and provoke some serious injuries.**



#### **WARNING**

IF SOME SPARKS OR AN ELECTRIC DISCHARGE WERE PERCEIVED, INTERRUPT IMMEDIATELY ALL PAINTING OPERATIONS.  
DO NOT USE THE SYSTEM UNTIL THE PROBLEM CAUSE IS IDENTIFIED.

Keep away from the working area all kinds of waste, of solvent container, of solvent or petrol soaked rags or clothes.

Before starting the system disconnect all the electrical connections inside the working area.

Before using the system switch off all the naked flames and pilot lights inside the working area.

Do not smoke inside the working area.

During painting operations, or if there are some vapours in the air, do not switch on or off the lights inside the working area.

Do not use any petrol engine inside the working area.

Some organic solvents or discharged toxic vapours can enter the eyes or the skin, be swallowed or inhaled, by provoking serious injuries.

When the air engine is running, keep the face away from the exhaust.



## 5.8 Pressure release process



### WARNING

1. Close the air to the gun.
2. Close the air to the pump (three-way valve).
3. Make sure the recirculation pipe is not clogged. Then open gradually the recirculation two-way valve and leave it open.
4. Hold the gun tightly and lean it on the earthed metal container, pull the trigger to release the pressure. If an automatic gun is used, supply the rod opening control with some air under pressure.



### PRECAUTIONS

1. To operate the pump, use some filtered air by means of an air filter with filtering section lower than 50  $\mu\text{m}$ . We recommend using a filter with condensate automatic discharge.
2. If possible, avoid using lubricated air which could damage the change-over valve.  

If the air is lubricated, it is advisable to use turbine oil ISO VG 32 or VG 46. Other types of oil could damage the air unit rubber gaskets.

If the pump has already been used with lubricated air, go on using it.
3. Do not make the pump idle.
4. Do not spray any paint or solvent towards the pump.
5. Do not install the pump near heat sources or in the sun. Put it far from sprinklings of water.
6. To avoid any problem after using bi-component paints, wash the pump immediately after using it otherwise all fluid passages could be clogged and the whole installation will have to be disassembled.





### 6.1

#### General notes



A suitable maintenance is important for a longer duration of the equipment in good working conditions and efficiency ensuring functional safety as time goes by. All maintenance operations must be carried out by a qualified staff. The pump design and the materials used to manufacture it limit the maintenance interventions to a simple periodic cleaning.

The staff must be provided with the individual protections that are generally used for similar operations. They also must follow the safety rules described in section 6.2.

### 6.2

#### Safety rules during maintenance

The main rules to follow during maintenance interventions on the unit are:

1. Disconnect the pneumatic supply before replacing any component.
2. Do not wear rings, watches, chains, bracelets, etc. during maintenance operations.
3. Always use the individual protections (gloves, safety shoes, etc.).
4. Do not use naked flames, points or pins for cleaning.
5. Do not smoke.

### 6.3

#### Recommended programmed operations

##### Every 50 working hours

Disassemble and clean the delivery and suction filters as well as the fluid passage ducts.

**Note:** If highly pigmented paints or paints with many particles tending to deposit are used, carry out maintenance operations at shorter intervals.

##### Every 2000 working hours

Overhaul the whole painting unit and replace the worn components.

The component corrosion speed varies according to the type of paint and the working conditions. To replace the worn components, follow the given instructions.

### 6.4

#### Diaphragm pump disassembly from its base support

#### PRECAUTIONS



Before disassembling the pump, follow carefully the instructions below:

- a) while disassembling the pump, avoid damaging the sealing rings, the diaphragms and the gaskets
- b) To disassemble and reassemble the manifolds 1-45 - 1-46 and the pump covers 1-24 use a 5 mm Allen wrench and a 10 mm spanner.
- c) Disassemble, in this order, the intake manifold 1-46, the delivery manifold 1-45, the side covers 1-24, by unscrewing the socket head screw by means of the suitable spanners.



1. Refer to the PRECAUTIONS FOR THE OPERATOR about the pressure release process on page 32.
2. Disconnect the pump from the compressed air supply.
3. Disassemble the suction filter system from the pump.
4. Remove the recirculation pipe.
5. Disassemble the PR 3E (or PR5) fluid pressure reducer from the pump.
6. Disassemble the pump casing (1-43) from the support base by removing the four special screws.
7. Remove the intake manifold (1-46), the delivery manifold (1-45) and the cover by following this order.



## PRECAUTIONS

Some paint residues could remain inside the PR 3E (or inside the PR5) paint pressure regulator: discharge them into the paint tank by overturning the pressure regulator itself.

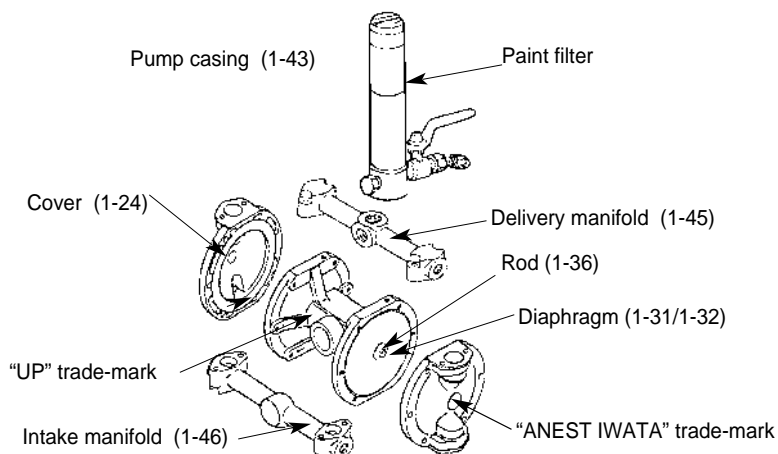

## 6.5 Double pneumatic valve disassembly

1. Unscrew the 2 screws (1-40 on page 51) and disassemble the double pneumatic valve protective cover (Pos. 1-39 on page 51).
2. Unscrew the 2 screws (Pos. 1-52 on page 51) supporting the double pneumatic valve and remove it.

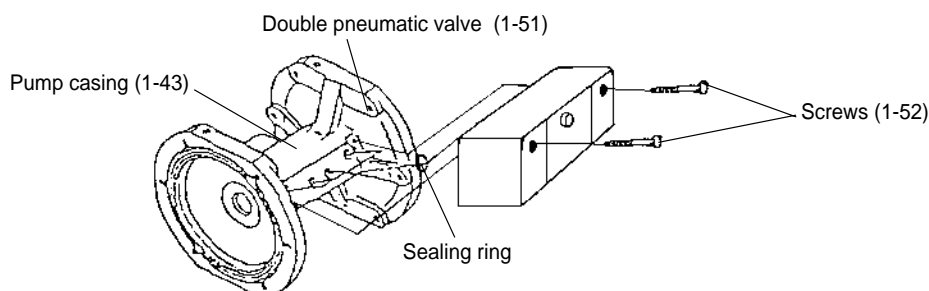



## 6.6 Diaphragm disassembly

- a) By means of 2 13 mm spanners remove the diaphragm stop nut (1-27) on a side only

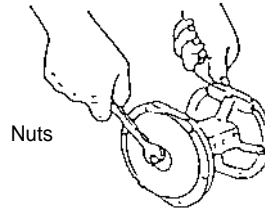

- b) Remove the washer (1-28), the diaphragm seat (1-29), the sealing ring (1-30), the diaphragm (1-31), the diaphragm (1-32) and the diaphragm seat (1-33).

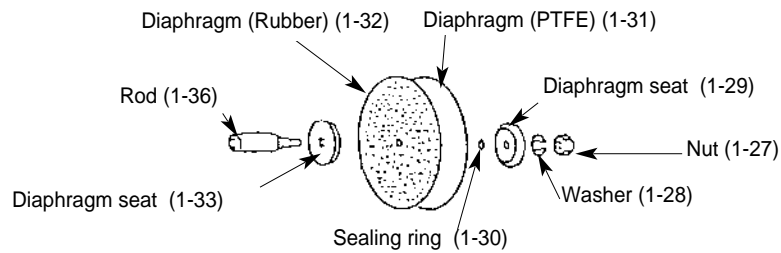

- c) Disassemble the rod (1-36) by pressing on the screw and by pulling from the opposite side towards the outside.

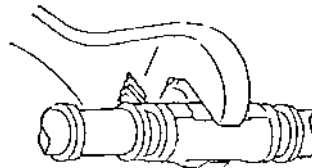

- d) Lock the rod centre (1-36) by means of a 12 mm spanner, loosen the nut on the side where the diaphragm has not been removed yet and disassemble as described in point b).

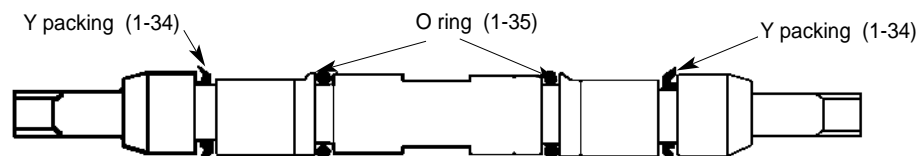

- e) Remove the sealing rings (1-35) and the Y packings (1-34).



## 6.7 Diaphragm reassembly

- a) Reassemble in the opposite direction to disassembly.



### PRECAUTIONS

- a) Pay attention to the assembly direction of the Y packings (see the picture).  
 b) Lubricate the Y packing, the sealing ring and the slots with some lithium grease.  
 c) Tightening pressure of nuts (1-27): 8.83 Nm.

## 6.8 Delivery and suction valve disassembly

### a) SUCTION VALVE

By means of a brass bar push the steel ball (1-19) by avoiding scoring the ball and its seat (1-50).

### b) DELIVERY VALVE

Insert a finger into the valve and remove it.

## 6.9 Delivery and suction valve reassembly

### a) SUCTION VALVE

- Assemble the sealing ring (1-21) on the valve.
- Insert the ball (1-19).
- Insert the valve (1-50) into its seat.

### b) DELIVERY VALVE

- Assemble the sealing ring (1-21) on the valve.
- Insert the valve (1-20) into its seat.
- Insert the ball (1-19).

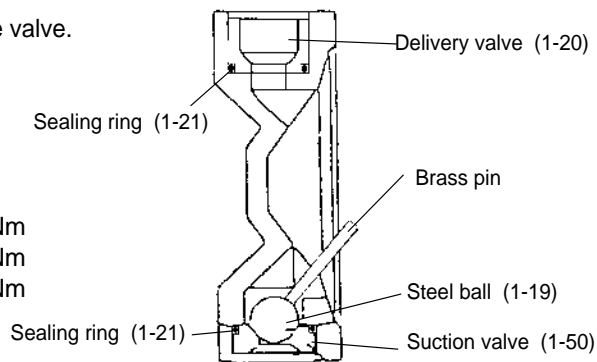

### Torque wrench setting

cover screws	7.35 Nm
delivery manifold screws	7.35 Nm
intake manifold screws	7.35 Nm

### Information for the operator

### PRECAUTIONS

When the side covers are reassembled on the pump casing, do not reverse the delivery side with the suction one.



## 6.10

### PR 3E fluid pressure regulator disassembly and maintenance

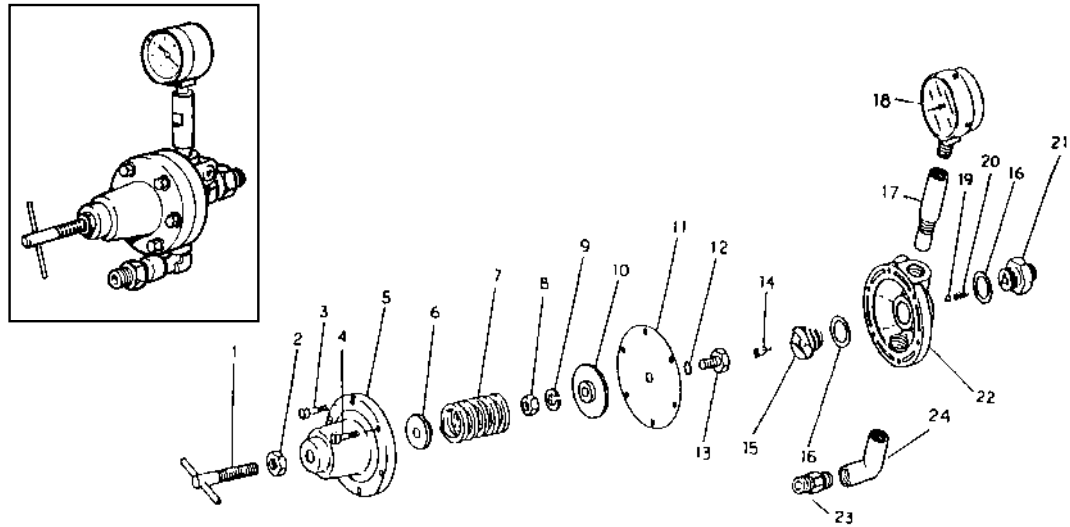

PAINT PRESSURE REGULATOR MODEL	PR 3E	PR 3E WB
Dimensions	160 x 80 x 220 mm	
Weight	920 g	
Fluid inlet	G 3/8"	
Fluid outlet	G 3/8"	
Max primary pressure	7.0 bar	
Fluid pressure setting range	from 0 to 3.0 bar	
Outgoing fluid maximum delivery	1.5 litres per min.	
Working temperature	from 5 to 40 °C	

#### 1. Diaphragm cover disassembly

1.1 Unscrew the screws (3) and remove the regulator cover (5), the spring press (6) and the spring (7).

1.2 Remove the whole diaphragm unit.

1.3 Remove the pin.

#### 2. Main casing disassembly

2.1 Unscrew the valve (15) by being careful not to lose the ball (19) and the spring (20).

2.2 Unscrew the rear connector (21).

#### 3. Diaphragm unit disassembly

3.1 Unscrew the nut (8) by means of a box wrench by preventing the screw (13) from moving.



#### 4. Inspection and replacements

- |                                  |   |
|----------------------------------|---|
| 4.1 Pin (14)                     | Replace if worn.  |
| 4.2 Ball (19)                    | Replace if scratched or dented  |
| 4.3 Spring (20)                  | Replace if the pin or the ball are replaced   |
| 4.4 Gaskets (16) and O ring (12) | Replace every time the regulator is disassembled                                    |
| 4.5 Diaphragm (11)               | Replace if damaged  |
| 4.6 Main casing (22)             | Clean by removing the paint or the residues with some thinner and a non metal brush |
| 4.7 Valve (15)                   | Clean with some thinner and a non metal brush                                       |
| 4.8 Connector (21)               | Clean with some thinner and a non metal brush                                       |

### 6.11 PR 3E fluid pressure regulator reassembly

#### 1. Diaphragm reassembly.

- 1.1 Assemble the O ring (12) on the screw (13).
- 1.2 Assemble the diaphragm (11) on the screw (13)



#### **PRECAUTIONS**

**Assemble the diaphragm (11) with the transparent resin surface opposed to the spring (7).**

- 1.3 Assemble the spring washer (9) and the nut (8), and tighten.



#### **PRECAUTIONS**

**Do not tighten the nut firmly (tightening force max. 3.67 Nm).**

#### 2. Main casing reassembly.

- 2.1 Assemble the gasket (16) on the connector (21).
- 2.2 Screw (3 thread turns) the connector (21) on the casing (22).
- 2.3 Put the spring (20) and the ball (19) inside the connector (21).
- 2.4 Assemble the gasket (16) on the valve (15).
- 2.5 Assemble the valve (15) and at the same time tighten the connector (21).
- 2.6 Assemble the pin (14).



### **PRECAUTIONS**

To reassemble the main casing follow the above-mentioned instructions to avoid damaging the spring (20), the tungsten carbide ball (19) and the tungsten carbide valve (15).

#### **3. Diaphragm cover reassembly.**

- 3.1 Place the preassembled diaphragm unit with the diaphragm holes near the main casing holes.
- 3.2 Assemble the spring (7) and the spring press (6).
- 3.3 Make sure that the screw (1) is completely unscrewed.
- 3.4 Assemble the regulator cover (5), the screws (3) and the washers (4).
- 3.5 Tighten the screws (3).



6.12 PR 5 fluid pressure regulator disassembly and maintenance

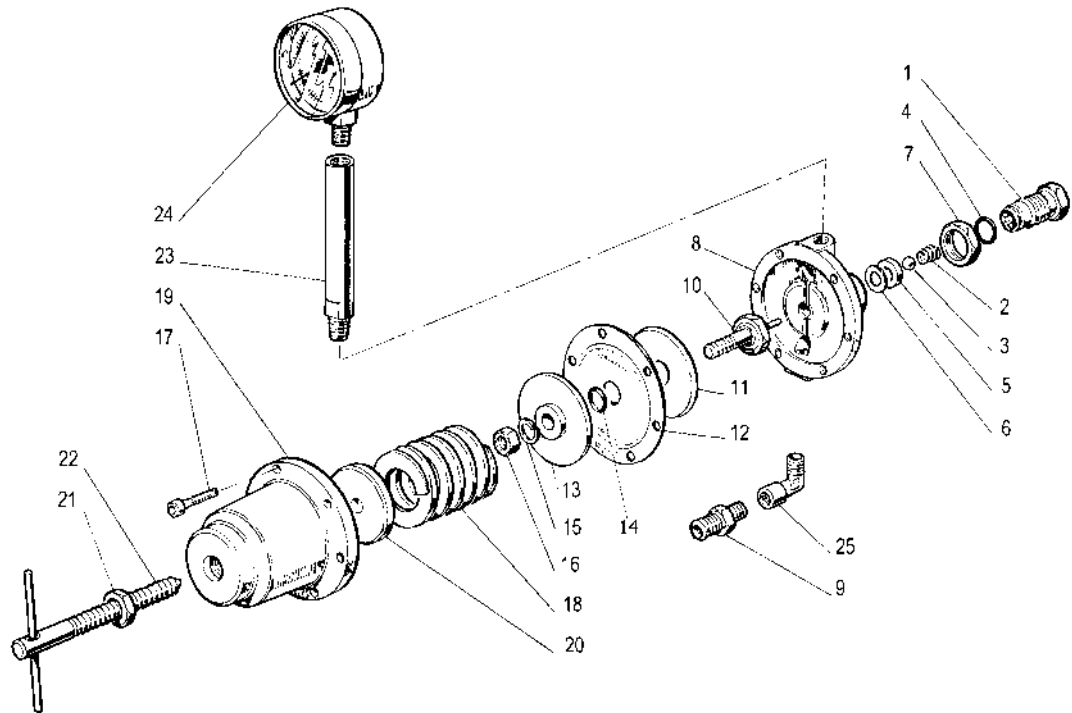

MODEL	PR5
Weight	850 g
Max. flow	2.0 l/min
Max. primary pressure	25.0 bar
Pressure range	6.0 bar
Connection IN	G 3/8"
Connection OUT	G 1/4"





## IMPORTANT



When you disassemble main body, rising pipe and pressure gauge, apply sealing agent to each threaded section to keep airtightness.



Whenever disassembling ball and seat of tungsten carbide, you have to be sure to confirm that there is no wear or damage. If there is any wear or damage, replace with new one.

## Disassembling

1. Fully loosen handle set (22), and remove bolt with hex. hole (17), diaphragm cap (19), spring holder (20), adjusting spring (18) and diaphragm section.
2. Loosen jam nut (7), and remove joint (1), valve spring (2), ball (3), seat (5) and packing (6).
3. Fix hex. section of diaphragm bolt (10), and remove hex. nut (16), spring washer (15), diaphragm stopper (13), O ring (14), diaphragm (12) and diaphragm holder (11).
4. If O ring placed into joint is damaged or deformed, remove O ring from joint.

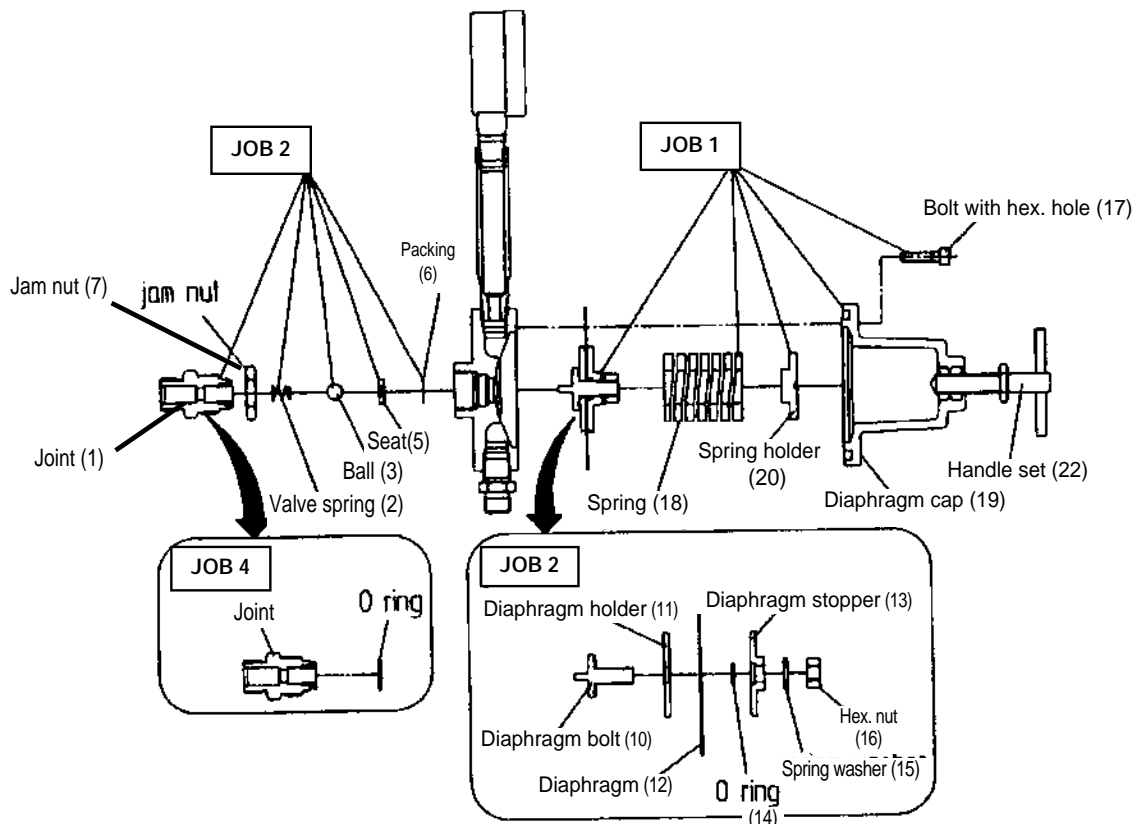



## 6.13 Assembling

1. Check on each section if there are damage and foreign matter .
2. Fit diaphragm holder (11), diaphragm (12), O ring (14), diaphragm holder (13) and spring washer (15) into diaphragm bolt (10) and tighten hex. nut (16). Tightening torque of hex. nut 9.8N-m
3. Mount diaphragm section, adjusting spring (18), spring holder (20), and diaphragm cap (19) on main body (8), and evenly tighten bolts with hex. bolt (17) diagonally.
4. Fit O ring (4) to joint (1).
5. Fit packing (6) and tungsten carbide seat (5) to body (8).
6. Fit valve spring (2) and ball (3) to joint (1), and then fit joint (1) to body (8). Tightening torque of joint 14.7N-m
7. Fix joint (1) with jam nut (7).

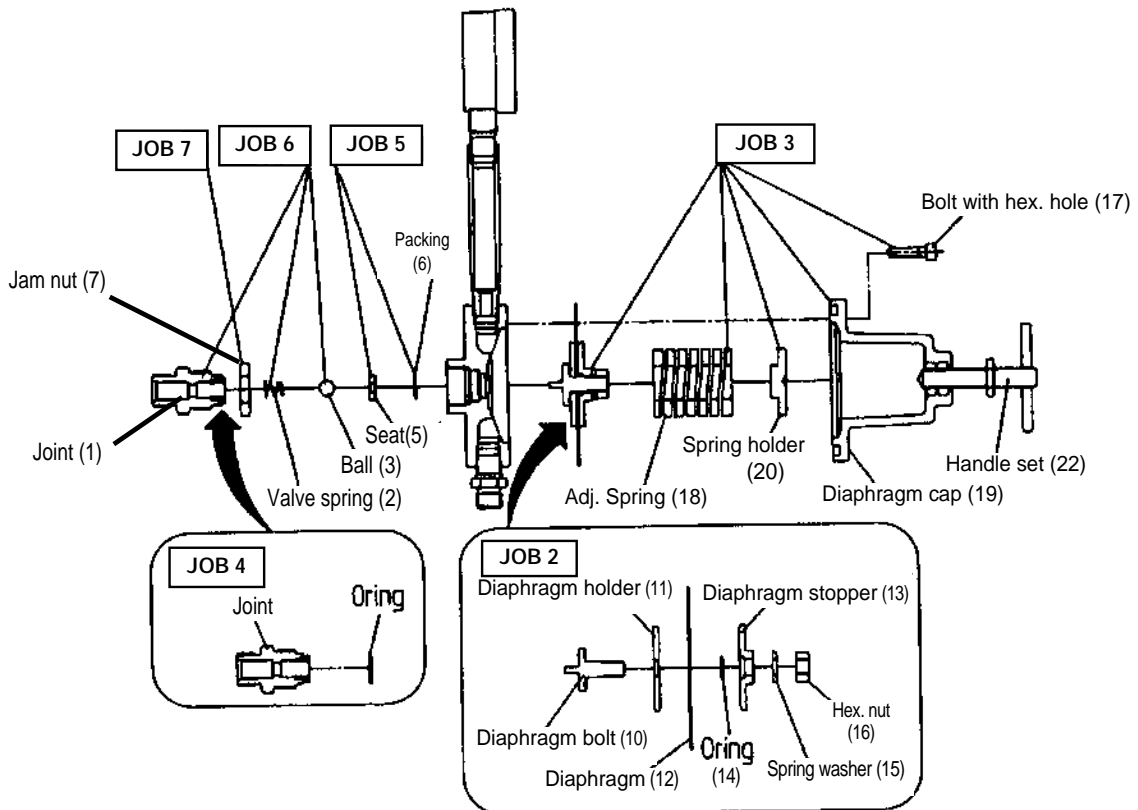



## IMPORTANT



Fit tungsten carbide seat to main body so that tungsten carbide ball can be fitted on tapered side. Do not forget to fit packing.

Wrong assembling can cause wrong movement of pointer of pressure gauge due to leakage from seat, failing performance.



Pay attention to tightening torque when fitting joint (1).

Too much tightening can damage main body.

Tightening torque of joint 14.7 N-m

When fitting joint, pay attention that tungsten carbide ball does not slip out of the seat.

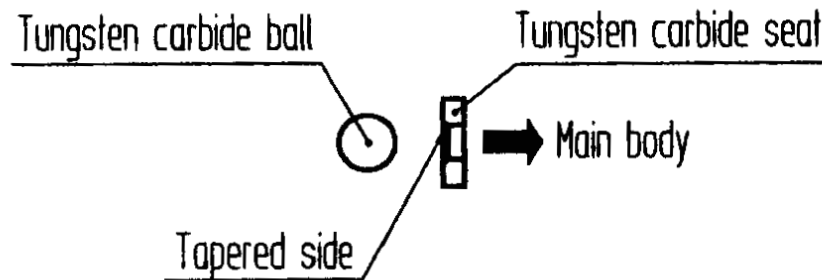

## 6.14 Paint filter maintenance

If the pump is used correctly (that is it is washed carefully each time it is used), the paint filter needs no special maintenance, with the exception of cleaning and filter replacement.

If there are some solidified paints inside the filter itself or inside the paint passages, disassemble it completely, clean it carefully and reassemble it.

During this operation pay attention to:

- Place the filter casing vertically
- Fasten the filter casing on the delivery manifold by means of the filter valve (1-6 on page 51). Put the LOCTITE 542 adhesive on the thread and replace the "NYLON" gasket between the two parts.

Make sure the valve inner part is clean and the ball can move.



**The pump does not work, it stops or does not restart.**

## 7.1 DDP 90 D DOUBLE DIAPHRAGM PUMP

### 1 Check the air sources:

- a) The compressed air does not reach the pump air inlet
- b) The air pressure is too low to start the pump
- c) The three-way valve (3-1) is in discharging position
- d) The air regulator is closed

- a) Connect the compressed air.
- b) Supply a sufficient air pressure (minimum 2,0 bar).
- c) Turn the valve in the right position.
- d) Open the air regulator.

### 2 The PR 3E (or PR5) pressure regulator is closed

**Open the PR3 E (or PR5) pressure regulator**

### 3 The silencer (1-37) is clogged

**Replace the silencer.**

### 4 The following parts are clogged because of solidified paint inside them?

- a) Fluid filter inside the paint filter
- b) Every pump fluid passage
- c) Every paint regulator fluid passage

- a) Clean and replace the fluid filter.
- b) Remove the clogging material.
- c) Remove the clogging material.

### 5 The pump does not run when the reset push button on the double pneumatic valve is pressed

**Disassemble the pump and check the following parts which will be replaced if damaged:**

- a) PTFE diaphragm (1-31).
- b) Rubber diaphragm (1-32).
- c) Y packings (1-34).
- d) O ring.
- e) Rod (any strange deformation, scratches or burrs).
- f) Self-lubricating bushings.
- g) Main casing inside diameters (Ø 15) damaged (scratched or with burrs).

**Replace the double pneumatic valve.**



**The pump works, but the fluid does not come out.**

**1 The following parts are unscrewed or damaged**

- a) The pump suction connector (1-47) with the suction pipe
- b) The suction connector (1-47)
- c) The intake manifold (1-46)
- d) The dip tube suction pipe

- a) Check if some tightening are loosened and tighten them.
- b) Put some adhesive and tighten.
- c) Tighten.
- d) If the suction pipe is damaged (it sucks air), replace it.

**2 The pressure regulator, the recirculation two-way valve and the gun are closed?**

**Open the pressure regulator and then the gun and the recirculation two-way valve**

**3 The following parts are clogged with some solidified paint residues?**

- a) The paint filter fluid filter (1-4)
- b) The dip tube suction pipe filter
- c) The dip tube suction pipe
- d) All the pump fluid passages
- e) All the paint regulator fluid passages

- a) Clean and replace the filter.
- b) Clean and replace the filter.
- c) Remove the solidified part.
- d) Remove the solidified part.
- e) Remove the solidified part.

**4**  
a) The upper and lower balls are stuck?  
b) The ball inside the paint filter is stuck?

- a) Clean the surfaces and release them.
- b) Clean the surface and release it.

**5 The following parts are damaged or worn**

- a) The ball seats (delivery and suction valves)
- b) The balls (1-19)
- c) The O rings of each ball seat
- d) The PTFE diaphragms

- a) Replace them.
- b) Replace them.
- c) Replace them.
- d) Replace them.

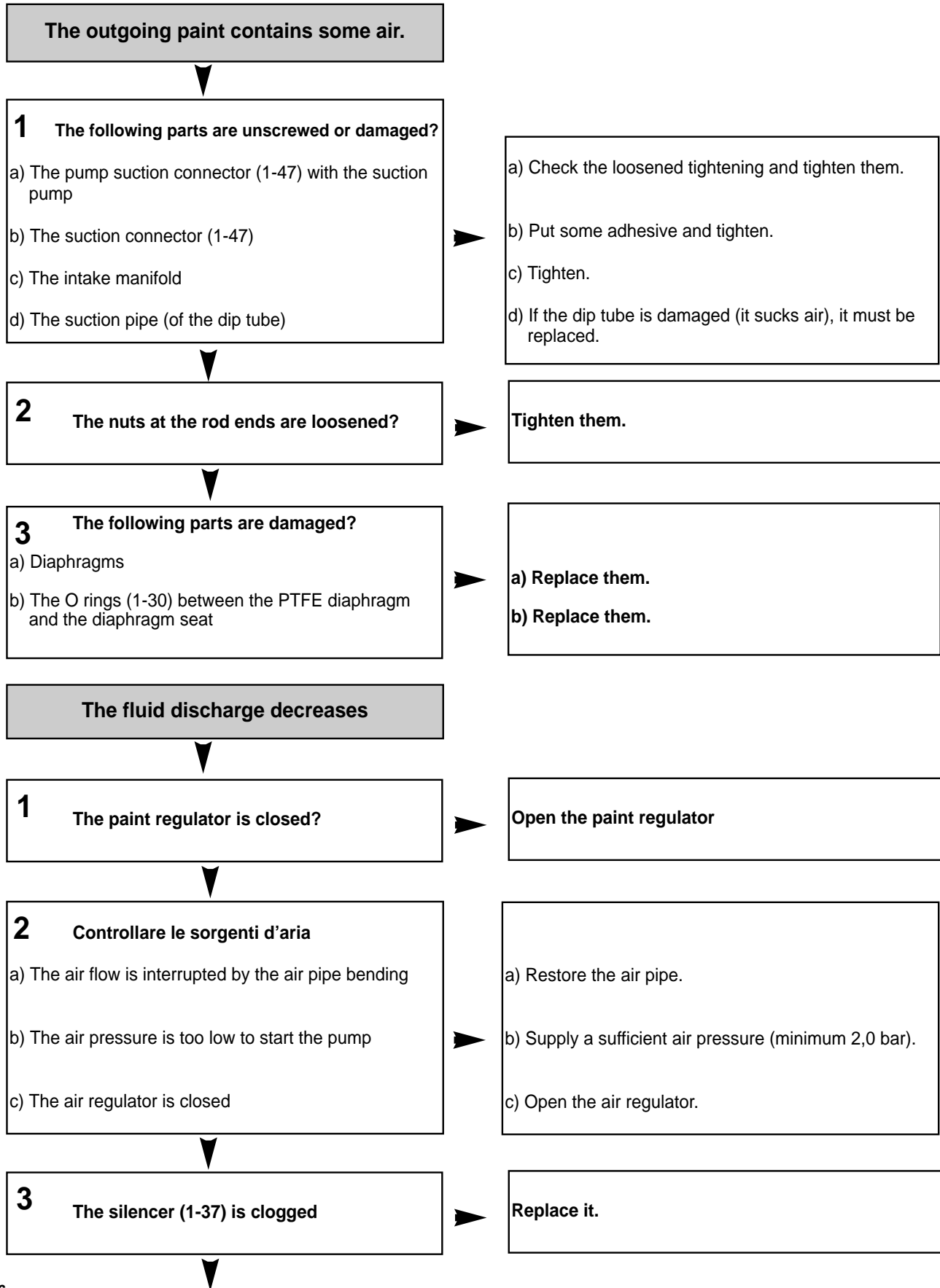



**4** The following parts are clogged with some solidified paint?

- a) The filter inside the paint filter
- b) The suction pipe filter (of the dip tube)
- c) The suction pipe (of the dip tube)
- d) All the pump material passages
- e) All the paint regulator material passages



- a) Clean and replace the filter.
- b) Clean and replace the filter.
- c) Remove the solidified part.
- d) Remove the solidified part.
- e) Remove the solidified part.



**5** The following parts are damaged or worn?

- a) The ball seats
- b) The balls (1-19)
- c) The PTFE diaphragms



- a) Replace them.
- b) Replace them.
- c) Replace them.



## 7.2 PR 3E PAINT REGULATOR

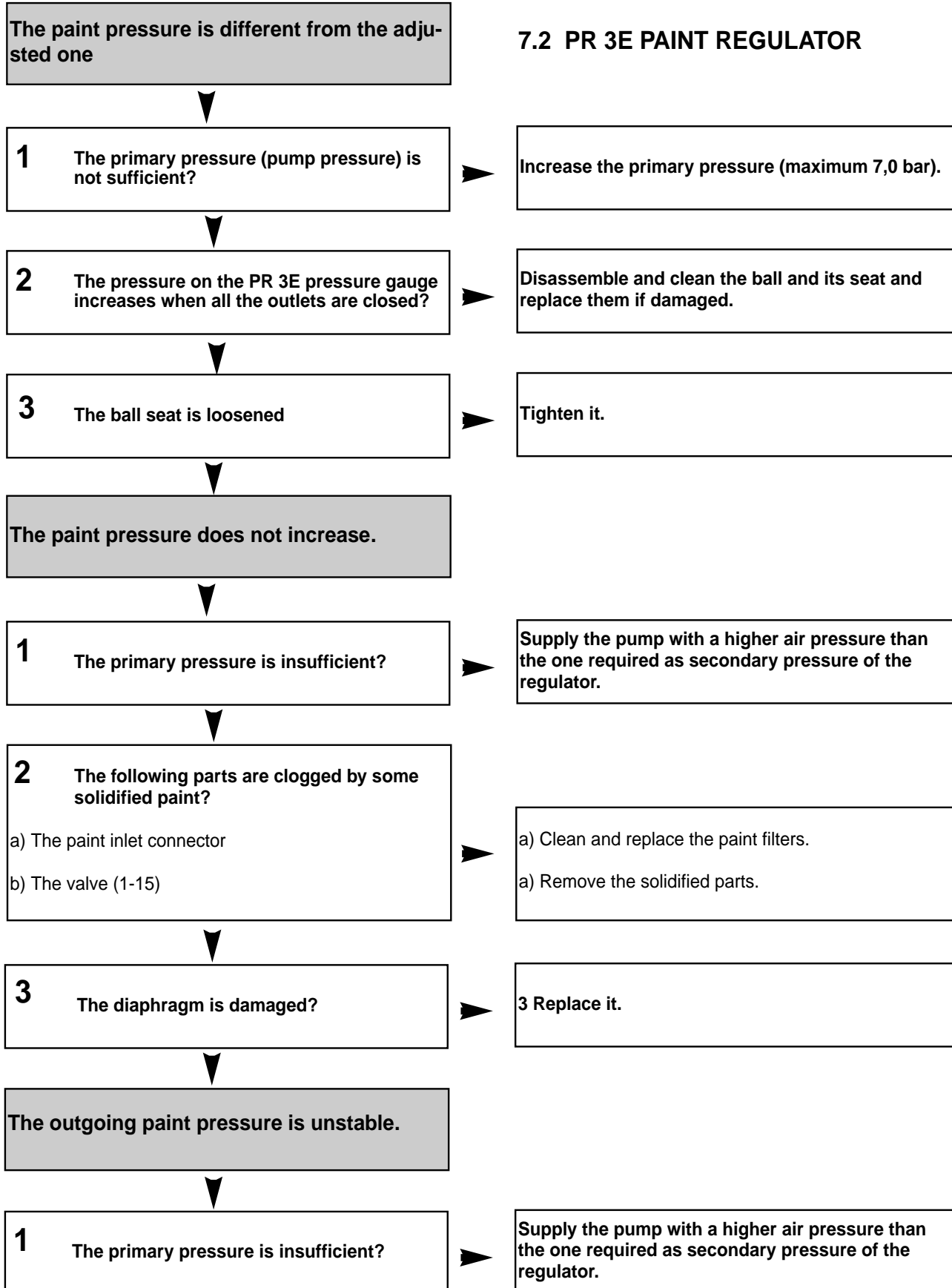





### 7.3 PR 5 PAINT REGULATOR

PROBLEMS	CAUSES	REMEDIS
<b>The pointer of pressure gauge sur- passes max. pressure.</b>	<ol style="list-style-type: none"><li>1. Not properly seated, or foreign matter</li><li>2. Wear or damage on seat</li><li>3. Wear and damage on ball</li><li>4. Seat packing (6) damaged</li></ol>	<ol style="list-style-type: none"><li>1. Clean and assemble again.</li><li>2. Replace tungsten carbide seat (5)</li><li>3. Replace tungsten carbide ball (3)</li><li>4. Replace packing (6)</li></ol>
<b>Paint leaks outside</b>	<ol style="list-style-type: none"><li>1. Loose joint (1)</li><li>2. Loose bolt with hex. hole (17)</li><li>3. Loose nut (16)</li><li>4. Diaphragm (12) damaged</li><li>5. O ring (4) damaged</li></ol>	<ol style="list-style-type: none"><li>1. Tighten</li><li>2. Tighten</li><li>3. Tighten</li><li>4. Replace diaphragm (12)</li><li>5. Replace O ring (4)</li></ol>
<b>Secondary pressure does not rise</b>	<ol style="list-style-type: none"><li>1. Primary pressure is too low</li><li>2. Failure of pressure gauge (24)</li><li>3. Paint hardened in rising pipe (23)</li></ol>	<ol style="list-style-type: none"><li>1. Raise primary side pressure</li><li>2. Replace pressure gauge (24)</li><li>3. Clean paint out</li></ol>
<b>Pressure is unstable</b>	<ol style="list-style-type: none"><li>1. Damage to valve spring (2)</li></ol>	<ol style="list-style-type: none"><li>1. Replace valve spring (2)</li></ol>



### 8.1 DDP 90 D – DDP 90 CE WB DIAPHRAGM PUMP

Pos.	DESCRIPTION	QUANTITY
1-1	CYLINDER	1
1-2	CAP	1
1-3	FILTER SCREW	1
1-4	● FILTER	1
1-5	BALL	1
1-6	FILTER VALVE	1
1-7	● GASKET	1
1-8	● GASKET	1
1-9	M 1/4" CONNECTOR	1
1-10	TWO-WAY VALVE FOR PAINT RECIRCULATION	1
1-11	90° CONNECTOR	1
1-12	SPRING PIN	1
1-13	FILTER CASING	1
1-14	FILTER PLUG	1
1-15	SCREW	8
1-16	WASHER	20
1-17	CAP	4
1-18	● GASKET	2
1-19	● BALL	2
1-20	● DELIVERY VALVE	1
1-21	● SEALING RING	4
1-22	SWIVEL CONNECTOR	1
1-23	SCREW	8
1-24	COVER	2
1-25	PLUG	1
1-27	HEXAGON NUT	2
1-28	WASHER	2
1-29	DIAPHRAGM SEAT	2
1-30	● SEALING RING	2
1-31	● PTFE DIAPHRAGM (PAINT)	2
1-32	● RUBBER DIAPHRAGM (AIR)	2
1-33	DIAPHRAGM SEAT	2
1-34	● Y PACKING	2
1-35	● SEALING RING	2
1-36	ROD	1
1-37	SILENCER	2
1-38	SUPPLY CONNECTION	1
1-39	VALVE PROTECTION	1
1-40	SCREW	2
1-41	SHEET	1
1-42	SCREW	2
1-43	□ PUMP CASING	1
1-44	SELF-LUBRICATING BUSHINGS	2
1-45	DELIVERY MANIFOLD	1
1-46	INTAKE MANIFOLD	1
1-47	SUCTION CONNECTOR	1
1-49	● O-RING	4
1-50	● SUCTION VALVE	1
1-51	DOUBLE PNEUMATIC VALVE	1
1-52	SCREW	2
1-53	WASHER	2

● Parts subject to wear

□ To replace the self-lubricating bushings, apply to your dealer.



# DDP 90 D - DDP 90 CE WB DIAPHRAGM PUMP

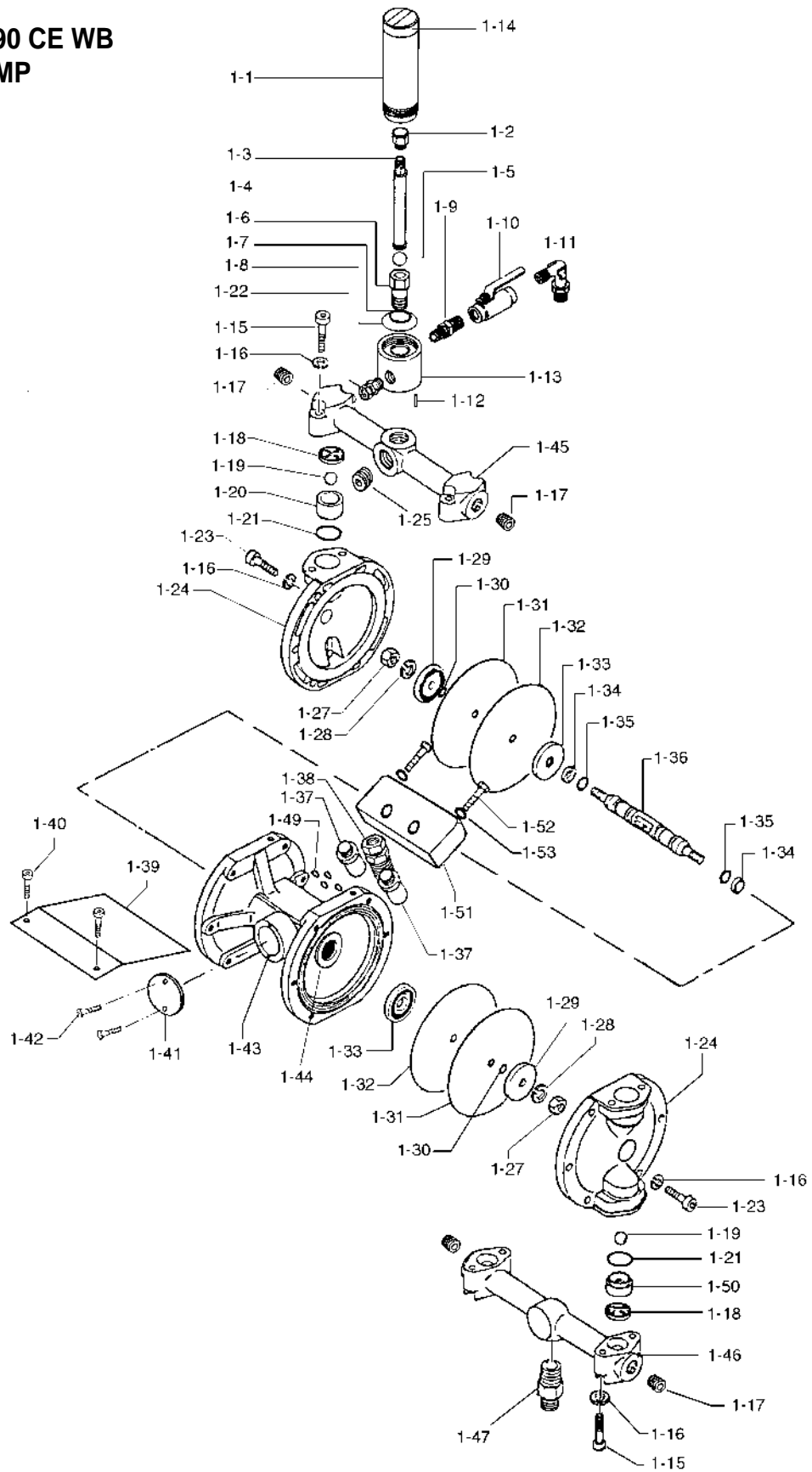

## 8.2 PR 3E / PR 3WB PAINT PRESSURE REGULATOR

DESCRIPTION	Pos.
ADJUSTING SCREW	1
NUT	2
SCREW	3
WASHER	4
REGULATOR COVER	5
SPRING PRESS	6
SPRING	7
NUT	8
WASHER	9
DIAPHRAGM SEAT	10
DIAPHRAGM	11 ○
O RING	12 ○
SCREW	13
PIN	14
VALVE	15 ○
GASKET 2 pieces	16 ○
PRESSURE GAUGE COLUMN	17
PRESSURE GAUGE	18
BALL	19 ○
SPRING	20 ○
CONNECTOR	21
REGULATOR CASING	22
FLUID CONNECTOR	23
90° CONNECTOR	24

○ Parts subject to wear

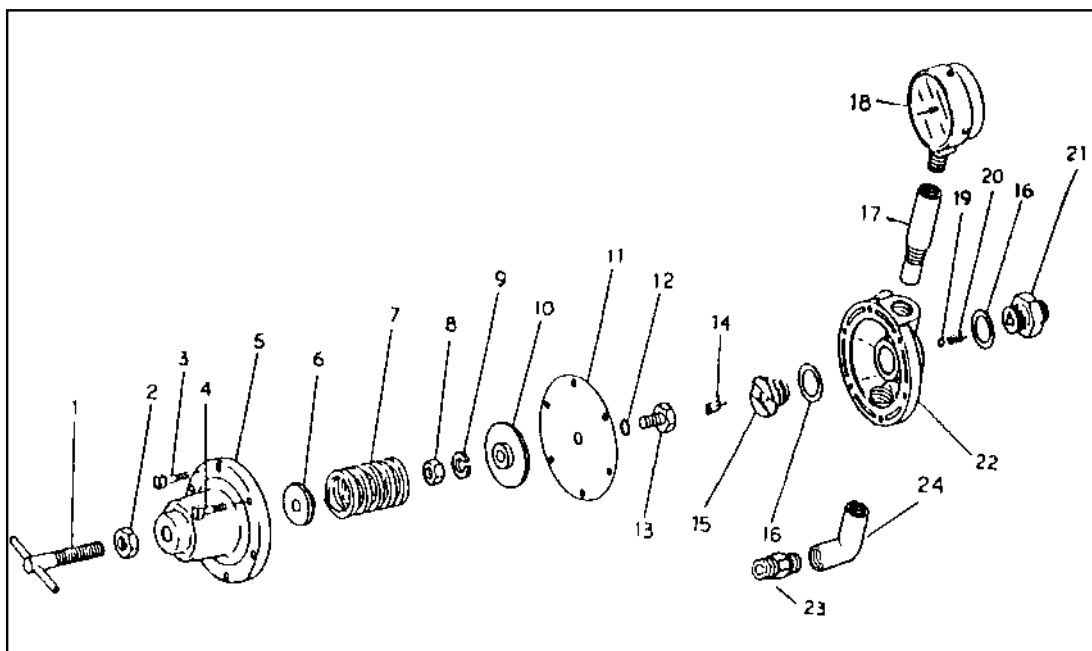



### 8.3 PR 5 PAINT PRESSURE REGULATOR

DESCRIPTION	Pos.
JOINT 3/8"	1
VALVE SPRING	2
BALL	3
O RING	4 ○
SEAT	5
PACKING	6 ○
JAM NUT	7
MAIN BODY	8
JOINT 1/4"	9
DIAPHRAGM BOLT	10
DIAPHRAGM HOLDER	11
DIAPHRAGM	12 ○
DIAPHRAGM STOPPER	13
O RING	14 ○
SPRING WASHER	15
HAXAGON NUT	16
BOLT WITH HEXAGON HOLE	17
SPRING	18
DIAPHRAGM CAP	19
SPRING HOLDER	20
HAXAGON NUT	21
HANDLE SET	22
RISING PIPE	23
PRESSURE GAUGE	24
"L" JOINT 1/4" MF	25

○ Parts subject to wear

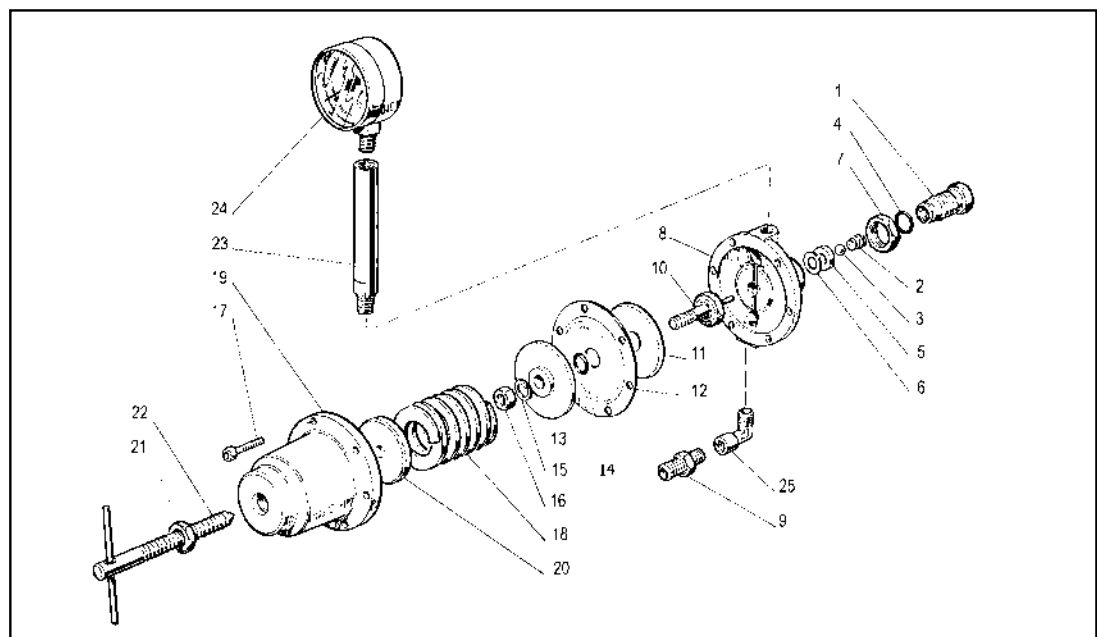



## 9.1 AIR ADJUSTING UNIT

Pos.	Description
3-1	THREE-WAY VALVE
3-2	1/4" M CONNECTOR
3-3	AIR PRESSURE REDUCER
3-4	1/4" M/F/M UNION TEE
3-5	PRESSURE GAUGE
3-6	90° 1/4" M CONNECTOR
3-7	1/4" M/M NIPPLE
3-8	SAFETY VALVE
3-9	1/4" F/M/F UNION TEE
3-10	AUTOMATIC COUPLING

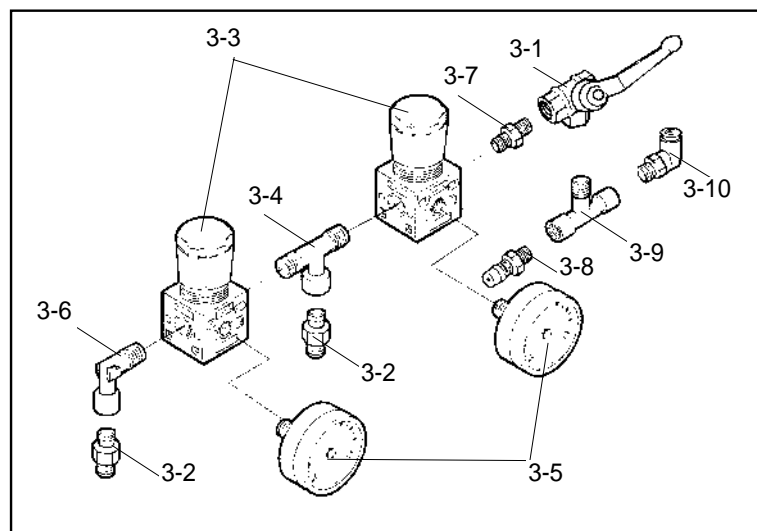

## 9.2 DIP TUBE WITH FILTER

Pos.	Description
<b>Picture 1</b>	<b>COMPLETE DIP TUBE</b> STAINLESS STEEL DIP TUBE
<b>Picture 2</b>	<b>COVER</b>
4-1	50 MESH FILTER
4-2	100 MESH FILTER (OPTIONAL)
4-3	SPRING
4-4	COMPLETE FILTER SET

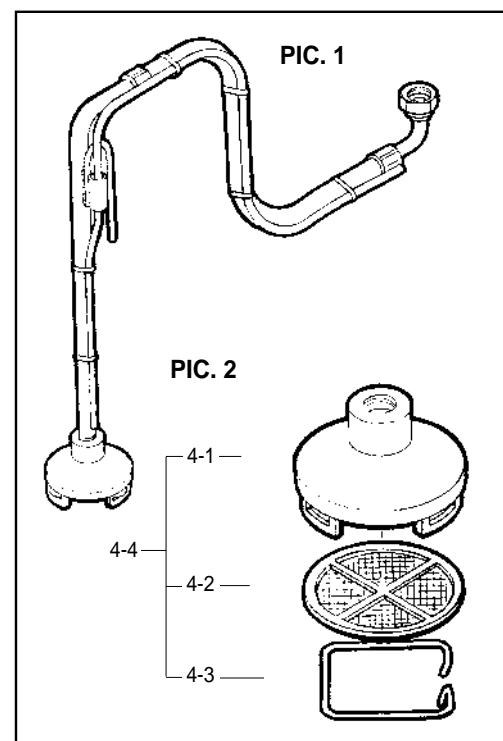



### 9.3

### SUPPORTS

Fig.	Description
1	WALL MOUNTING BRACKET
3	SUPPORT
4	TRAILER
5	TANK (20LITRES)

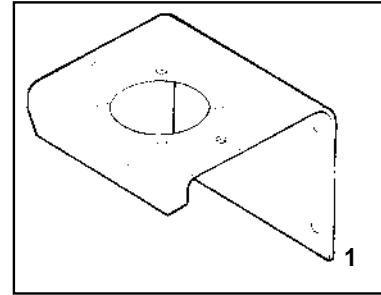

### 9.4

### HOPPER UNIT

Fig.	Description
6	HOPPER SET

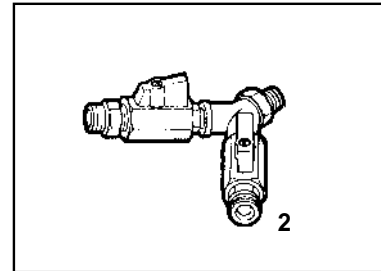

### 9.5

### WYE

Fig.	Description
2	WYE

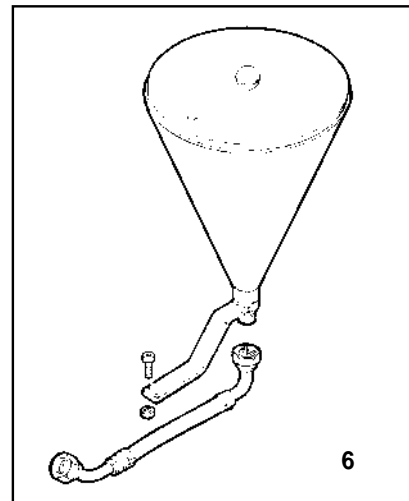
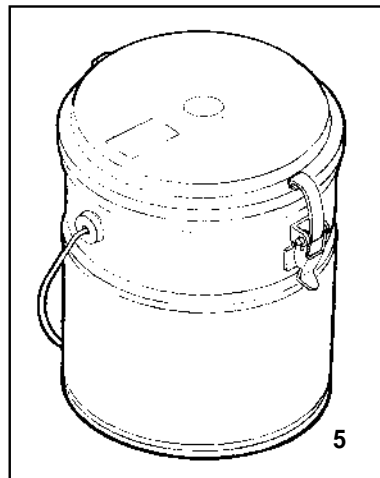
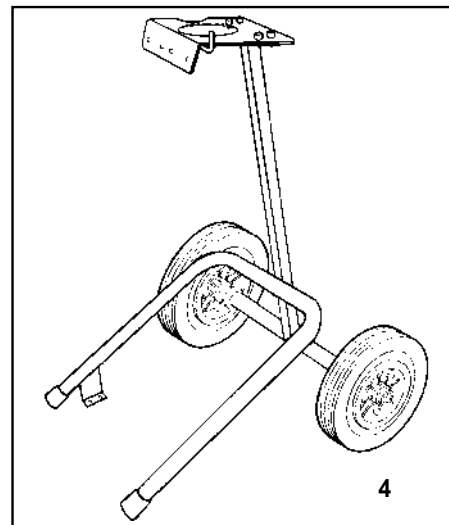
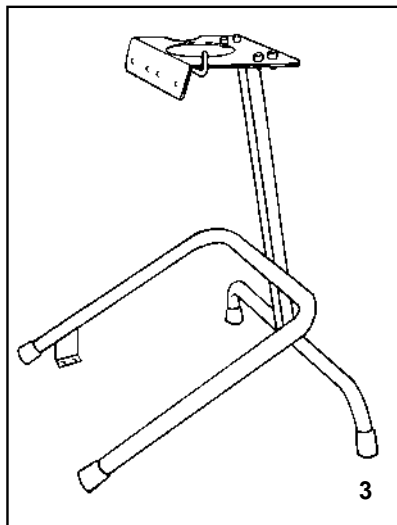



## 10.1 Equipment storage

If the diaphragm pump is to be stored for a certain period, the following operations are recommended:

Disconnect the equipment from the energy sources.

Remove all residues and deposits from the pump.

Cover the equipment with a waterproof tarpaulin.

---

## 10.2 Dismantling

If for any reason the pump is to be dismantled, some important rules have to be followed to safeguard the environment.

All sheaths, flexible ducts and plastic or non metal components will have to be disposed of separately.

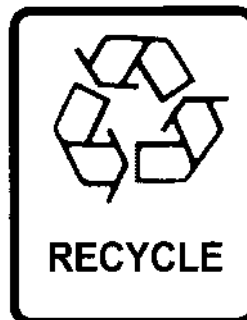











*European  
Sales  
Branches:*

**ANEST IWATA Europe s.r.l.**

46, Corso Vigevano  
10155 Torino - Italy  
Tel. +39 011-24 80 868  
Fax +39 011-85 19 44  
[www.anest-iwataeu.com](http://www.anest-iwataeu.com)  
e-mail: [info@anest-iwataeu.com](mailto:info@anest-iwataeu.com)

**ANEST IWATA Deutschland**

Trollingerweg 14  
D-74360 Ilsfeld-Auenstein  
Telefon-Fax:+49 (0)7062-62 290  
Handy: +49 (0)172-62 74 542  
[f.e.anest-iwata@t-online.de](mailto:f.e.anest-iwata@t-online.de)

---

**ANEST IWATA Scandinavia A.B.**

Ögärdesvägen 6C  
433 30 Partille  
Tel. +46 (0)31-340 28 60  
Fax +46 (0)31-340 28 69  
[info@anest-iwata.se](mailto:info@anest-iwata.se)

**ANEST IWATA France S.A.**

25 Rue de Madrid - BP 7405  
38074 Saint Quentin Fallavier  
Cedex Centre Evolic 7405  
Tél. +33 (0)4-74 94 59 69  
Fax +33 (0)4-74 94 34 39  
[info@anest-iwata.fr](mailto:info@anest-iwata.fr)

**ANEST IWATA (U.K.) LTD**

Unit 2, Cedar Trade Park,  
Ferndown Industrial Estate,  
Wimborne, Dorset - BH21 7SB U.K.  
Tel. +44 (0)1202 - 895999  
Fax: +44 (0)1202 - 895666  
[enquiries@anest-iwata.co.uk](mailto:enquiries@anest-iwata.co.uk)