

INSTRUCTION MANUAL

- Automatic Spray Guns **WRA-100 / WRA-200**
- Low Pressure Automatic Spray Gun **LRA-200** High Volume Low Pressure

Our products are produced as per international standards ISO9001

Important

This manual contains **IMPORTANT WARNINGS** and **INSTRUCTIONS**. Equipment in this manual is exclusively for painting purposes. Do not use for other purposes. The operator shall be fully conversant with the requirements stated in this instruction manual including important warnings, cautions and operation and correct handling. Read and understand the instruction manual, before use and retain for reference.

CE II 2G X

This Anest-iwata spray gun kit complies to ATEX regulations 94/9/EC,
Protection level :
II 2 G X, Suitable for use in Zones 1 and 2.
X marking :
Any static electricity discharge from the spray gun is to be diverted to the grounded the conductive air hose as stipulated.

Be sure to observe warnings and cautions in this instruction manual. If not, it can cause paint ejection and serious bodily injury by drawing organic solvent. Be sure to observe following marked items which are especially important.

WARNING	Indicates a potentially hazardous situation which, if not avoided, may result in serious injury or loss of life.
CAUTION	Indicates a potentially hazardous situation which, if not avoided, may result in minor or moderate injury or property damage.
Important	Indicates notes which we ask you to observe. The safety precautions in this instruction manual are the minimum necessary conditions. Follow national and local regulations regarding fire prevention, electricity and safety as well as your own company regulations.

Important specifications

Max. Pressure	0.69MPa / 6.8 bar / 98PSI
Noise level WRA-100	78 7dB(A)
-200	82 4dB(A)
LRA-200	76 9dB(A)
Spray condition	Recommended
Measuring point	1m backwards from gun, 1.6 m height
Max. Temperature	
Atmosphere	5°C ~ 40°C
Air • Fluid	5°C ~ 43°C

Main specifications

Model	Type of feed	Nozzle orifice φ mm (in)	Air cap Set Mark	Recommended condition					Air & fluid connection	Mass g (lbs)	
				※1 Air pressure MPa (bar /PSI)		Air pressure inside air cap MPa (bar /PSI)	Fluid output ml/min	Air consumption l/min (cfm)			Pattern width mm(in)
				Atomizing air	Fan air						
WRA-100-082P	Pressure	0.8 (0.031)	E2P	0.27 (2.7/38)	0.22 (2.2/31)	-	150	270 (9.5)	190 (7.5)	3-Rc1/4 (Air)	290 (0.64)
-200-122P		1.2 (0.047)	G2P	0.24 (2.4/34)	0.27 (2.7/38)	-	500	530 (18.7)	400 (15.7)		310 (0.68)
LRA-200-122P		1.2 (0.047)	G2	0.14 (1.4 /20)	0.16 (1.6/23)	0.07 (0.7 /10)	500	500 (17.7)	300 (11.8)	2-Rc1/4 (Fluid)	310 (0.68)

※1. Air pressure means air pressure at gun inlet when air valve is opened and air flows.

■ Safety precautions

⚠ WARNING

Fire and explosion

- Spark and open flames are strictly prohibited.**
Paints can be highly flammable and can cause fire.
Avoid any ignition sources such as smoking, open flames, electrical goods, etc.
- Never use the following HALOGENATED HYDROCARBON SOLVENTS**
which can cause cracks or dissolution on gun body (aluminum) by chemical reaction.
unsuitable solvents methyl chloride, dichloromethane, 1,2-dichloroethane, carbon tetrachloride, trichloroethylene, 1,1,1-trichloroethane
Be sure that all fluids and solvents are compatible with gun parts. We are ready to supply a material list used in the product)



3. Securely ground spray gun.

Use air hose with built-in ground wire or use grounded gun stay.
Ground resistance : Less than 1MΩ.
Check the earth stability periodically.
If not, insufficient grounding can cause fire and explosion due to static electric sparking.



Improper use of equipment

- Never point gun toward people or animal.**
If done, it can cause inflammation of eyes and skin or bodily injury.
- Never exceed maximum operating pressure and maximum operating Temperature.**



3. Be sure to release air and fluid pressures before cleaning, disassembling or servicing.

If not, remaining pressure can cause bodily injury due to improper operation or scattering cleaning liquid.
In order to release pressure, first stop supply of compressed air, fluid and thinner to spray gun.
Then remove fluid adj. knob and pull fluid needle set toward you.

4. Tip of fluid needle set has a sharp point.

Do not touch the tip of needle valve at the maintenance for the protection of the human body.

Protection of human body

- Use in a well-ventilated site by using spray booth.**
If not, poor ventilation can cause organic solvent poisoning and catch fire.
- Always wear protective gear (safety glasses, mask, gloves).**
If not, cleaning liquid, etc., can cause inflammation of eyes and skin.
If you feel something wrong with eyes or skin, immediately see a doctor.
- Wear earplugs if necessary.**
Noise level can exceed 85dB(A), depending on operating conditions and painting site



Other precautions

- Never alter this spray gun.**
If done, it can cause insufficient performance and failure.
- Enter working areas of other equipment (robots, reciprocators, etc.) after machines are turned off.** If not, contact with them can cause injury.

3. Never spray foods or chemicals through this gun.

If done, it can cause accident by corrosion of fluid passages or adversely affect health by mixed foreign matter.

- If something goes wrong, immediately stop operation and find the cause.** Do not use again until you have solved the problem.

■ How to connect

⚠ CAUTION

- Use clean air filtered through air dryer and air filter. . . If not, dirty air can cause painting failure.
- If you use this gun for the first time after purchasing, clean fluid passages spraying thinner and remove rust preventive oil.
If not, remaining preventive oil can cause painting failure such as fish eyes.
- Use three-way solenoid valve of more than φ 4 inner dia. cross-sectional area and air hose of over φ 6 inner dia. and less than 10m length.
If not, small dia. of solenoid valve and longer air hose between three-way solenoid valve and gun can cause delay in operation.
- Firmly fix hose to spray gun. . . If not, disconnection of hose and drop of container can cause bodily injury.

Job1. Fit the gun to fitting stay, aim at spraying direction and fix it.

Job2. Connect atomizing air hose to atomizing air side (Cap marked side) and operating air hose to operating air side (CYL marked side).

Job3. Connect fluid hose to fluid inlet tightly.

Job4. Flush the gun fluid passage with a compatible solvent.

Job5. Pour paint into fluid container, test spray and adjust fluid output, air volume and pattern width.

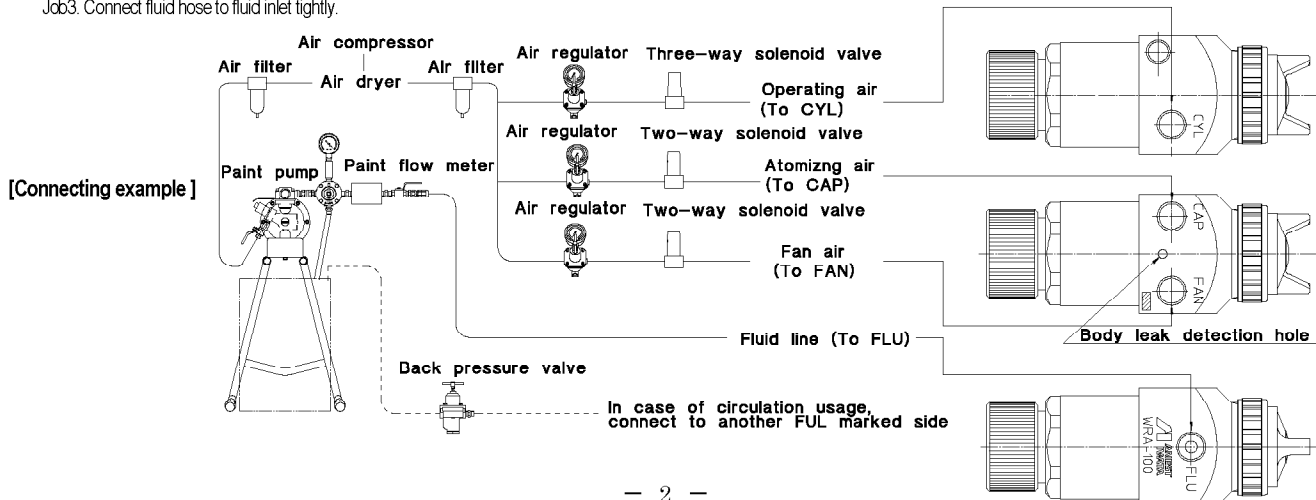

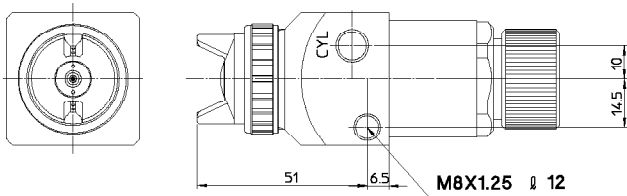

How to change unions for circulation usage. Thread for fitting the gun

Important	1. Remove hex. nut from gun body with 5mm allen wrench.
	2. Pull plug out with attached screw as standard accessory.
	3. Tighten commercial fitting joint tightly.
	4. Connect fluid hose to the joint.

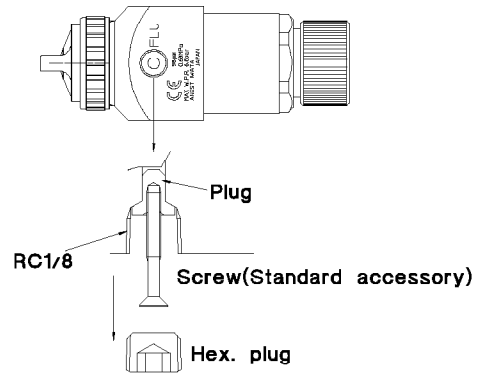

How to operate

Suggested air pressure is 3 to 4 bar (43 to 57 PSI).

NOTE:

Valve orifice inside three-way solenoid valve should be minimum ϕ 4mm (0.157 in) and also operating air hose length should be within 10m (32.8ft) with the inner diameter more than ϕ 6mm (0.236in) to avoid delayed operation and any kind of failure.

Recommended paint viscosity differs according to paint property and painting conditions. 15 to 23 sec/Ford cup# 4 is recommendable.

As LRA-200 is operate at low air pressure, high transfer efficiency will not be obtained if the spray distance is too far.

NOTE:

Using air hose 12m (39.4ft) long, the inner diameter must be a minimum 8mm (0.315) so the gun can have the correct air volume to atomize at 0.7 bar (10PSI) inside air cap.

Set the spray distance from the gun to the work piece as near as possible within the range of 150-250 mm (5.9-9.8 in) with WRA-100/ 200, 100-200mm (3.9-7.9in) with LRA-200.

Maintenance and inspection

WARNING

- First release air and pressure fully according to item No. 3 of "Improper use of equipment" of WARNING on page 2.
- Tip of fluid needle set has a sharp point. Do not touch the tip of needle valve at the maintenance for protection of the human body.
- Be careful not to damage the tip of fluid nozzle or must not put your hand on it.
- Only an experienced person who is fully conversant with the equipment can do maintenance and inspection.

CAUTION

- Never use commercial or other parts instead of ANEST IWATA original spare parts.
- Never immerse the whole gun into liquid such as thinner.
- Never damage holes of air cap a fluid nozzle and fluid needle.

Step-by-step procedure	Important
1. Pour remaining paint to another container. Clean fluid passages and air cap set. Spray a small amount of thinner to clean fluid passages.	1. Incomplete cleaning can fail pattern shape and uniform particles. Especially clean fully and promptly two-component paint after use.
2. Clean each section with brush soaked with thinner and wipe out with waste cloth.	2. Do not immerse the whole gun in thinner. If done, it can damage parts. When cleaning, never scratch each hole of air cap set and fluid nozzle, and fluid needle set.
3. Before disassembly, fully clean fluid passages. (1) Disassemble fluid nozzle. Use ring spanner, box wrench or optional exclusive spanner (code No.035386000) to disassemble fluid nozzle.	3. During disassembly, do not scratch seat section. (1) Remove fluid nozzle after removing fluid needle set or while keeping fluid needle pulled, in order to protect seat section.
(2) Disassemble fluid needle set. Remove fluid adj. set and pull out fluid needle set from gun body. Pay attention so that spring does not suddenly fly out since fluid adj. set is strongly pushed by fluid needle spring and piston spring.	(2) Pull fluid needle set after loosening fluid needle packing set to protect fluid needle packing set.

Where to inspect	Parts replacement standard
1. Each hole passage of air cap and fluid nozzle	Replace if it is crushed or deformed.
2. Packing and O ring	Replace if it is deformed or worn out.
3. Leakage from seat section between fluid nozzle and fluid needle set	Replace them if leakage does not stop after fully cleaning fluid nozzle and fluid needle set. If you replace fluid nozzle or fluid needle set only, fully match them and confirm that there is no leakage.

Parts list

When ordering parts, specify gun's model, part name with ref.No. and marked No. of air cap set, fluid nozzle and fluid needle set.

When replacing fluid nozzle or/and fluid needle for pressure feed application, please order fluid nozzle-needle set.

Fluid nozzle -fluid needle set combination

Model	Fluid nozzle		Fluid needle set mark
	Orifice ϕ mm(in)	Mark	
WRA -100	ϕ 0.8 (0.031)	WA100/08	WRA12
200	ϕ 1.2 (0.047)	WA200/12	
LRA -200	ϕ 1.2 (0.047)	L200/12	

No.	Description	Qty
1	Air cap set	1
2	Fluid nozzle-fluid needle set	1
3	Body set	1
4	Fluid needle packing set	1
5	Piston	1
6	Needle screw	1
7	Piston packing	1
8	Piston Spring	1
9	O ring	1
9-1	Stop ring	1
9-2	Ball	1
9-3	Fluid adj. spring	1
10	Plug	1
11	Hex. plug	1
12	Screw	1
13	Instruction manual	1

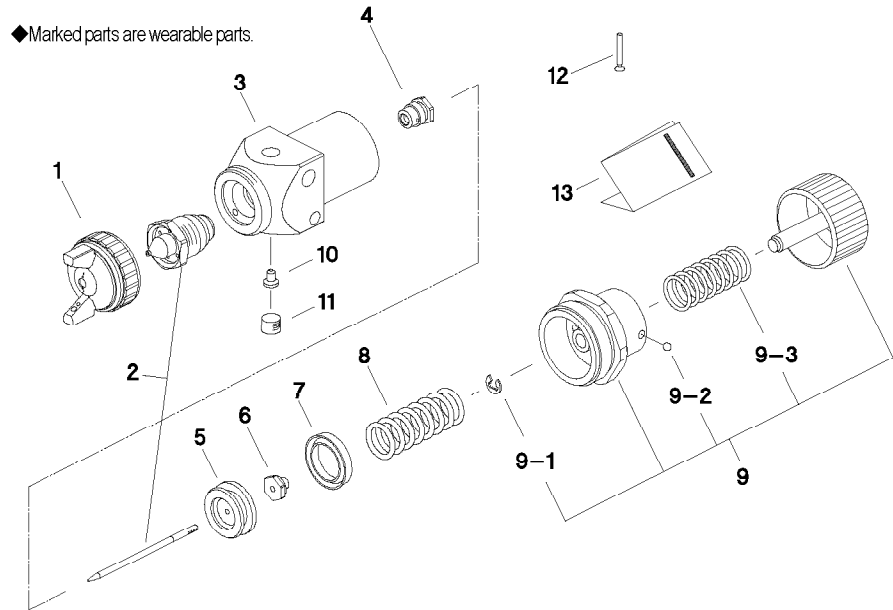

■ Troubleshooting

Spray Pattern	Problems	Remedies
Fluttering	<ol style="list-style-type: none"> Air enters between fluid nozzle and tapered seat of gun body. Air is drawn from fluid needle packing set. Air enters at fluid container fitting nut or fluid hose joint. 	<ol style="list-style-type: none"> Remove fluid nozzle to clean seat. If it is damaged, replace nozzle. Tighten fluid needle packing. Fully tighten joint section.
Crescent	<ol style="list-style-type: none"> Paint buildup on air cap partially clogs horn holes. Air pressure from both horns differs 	<ol style="list-style-type: none"> Remove obstructions from horn holes with attached brush. But do not use metal objects to clean horn holes
Inclined	<ol style="list-style-type: none"> Paint buildup or damage on fluid nozzle circumference and air cap center. Fluid nozzle is not properly fitted. 	<ol style="list-style-type: none"> Remove obstructions. Replace if damaged. Remove fluid nozzle and clean seat section.
Split	<ol style="list-style-type: none"> Paint viscosity too low. Fluid output too high. 	<ol style="list-style-type: none"> Add paint to increase viscosity. Tighten fluid adj. knob to reduce fluid output. Or turn pattern adj. valve set clockwise.
Heavy Center	<ol style="list-style-type: none"> Paint viscosity is too high. Fluid output is too low. 	<ol style="list-style-type: none"> Add thinner to reduce viscosity. Turn fluid adj. valve knob counter-clockwise to increase fluid output.
Spit	<ol style="list-style-type: none"> Fluid nozzle and fluid needle set are not seated properly. The first-stage travel of trigger (when only air discharges) decreases. Paint buildup inside air cap set. 	<ol style="list-style-type: none"> Clean or replace fluid nozzle and fluid needle set. Replace fluid nozzle and fluid needle set. Clean air cap set.

R1 : retighten R2 : adjust R3 : clean R4 : replace parts

Problem	Where it occurred	Parts to be checked	Cause	Remedy			
				R1	R2	R3	R4
Paint leaks	Fluid nozzle	Fluid nozzle ~ fluid needle	* Dirt or damage, wear on seat surface * Wear on needle spring			○	○
	Fluid needle packing	Fluid needle packing ~ packing seat	* Needle does not return due to paint buildup on fluid needle. * Wear * Insufficient tightening		○	○	○
Paint does not flow	Tip of gun	Fluid adj. knob.	* Insufficient opening		○		
		Tip hole of nozzle	* Clogged			○	
		Paint filter	* Clogged			○	○



ANEST IWATA Corporation

3176, Shinyosida-cho, Kohoku-ku, Yokohama, 223-8501, Japan

Code No. 03528623

No. 1056-05